

GROVER/TROPHY

DISTRIBUTOR CATALOG



Experience a family of brands
that have moved generations
since 1922.



**GROVER**
WORLD'S FINEST MACHINE HEADS



TROPHY
Music Co.



THE CLEVELAND DRUM COMPANY

Table Of Contents

GROVER

Finishes and Specifications..... Pg. 4
 Rotomatics..... Pg. 5
 Locking Rotomatics..... Pg. 8
 Locking Vintage..... Pg. 11
 Vintage..... Pg. 12
 Bass..... Pg. 15
 Pedal Steel & Classic Guitar..... Pg. 16
 Mandolin..... Pg. 17
 Banjo..... Pg. 18
 Ukulele..... Pg. 20
 Ukulele, Baritone Ukulele/Tenor Guitar..... Pg. 21
 Dulcimer & Violin Pegs..... Pg. 22
 Guitar Bridges..... Pg. 23
 Mandolin Bridges..... Pg. 24
 Banjo Bridges..... Pg. 25
 Cables..... Pg. 26
 Accessories..... Pg. 27
 Parts Trays..... Pg. 30

TROPHY

Wind Instruments..... Pg. 32
 Fun and Educational..... Pg. 41
 Fun and Educational Rhythm Kits..... Pg. 42
 Percussion..... Pg. 44
 Percussion Accessories..... Pg. 44
 Brass and Woodwind Accessories..... Pg. 72
 Just In Case Hardware..... Pg. 84
 Batons..... Pg. 86
 String Instruments..... Pg. 89
 String Accessories..... Pg. 93
 Viola, Cello and Bass Accessories..... Pg. 95
 Violin Accessories..... Pg. 99
 Novelty..... Pg. 102
 Displays..... Pg. 116

THE CLEVELANDER DRUM COMPANY

Mallets..... Pg. 124
 Mallet Bag and Cowbells..... Pg. 128
 Temple Blocks..... Pg. 129

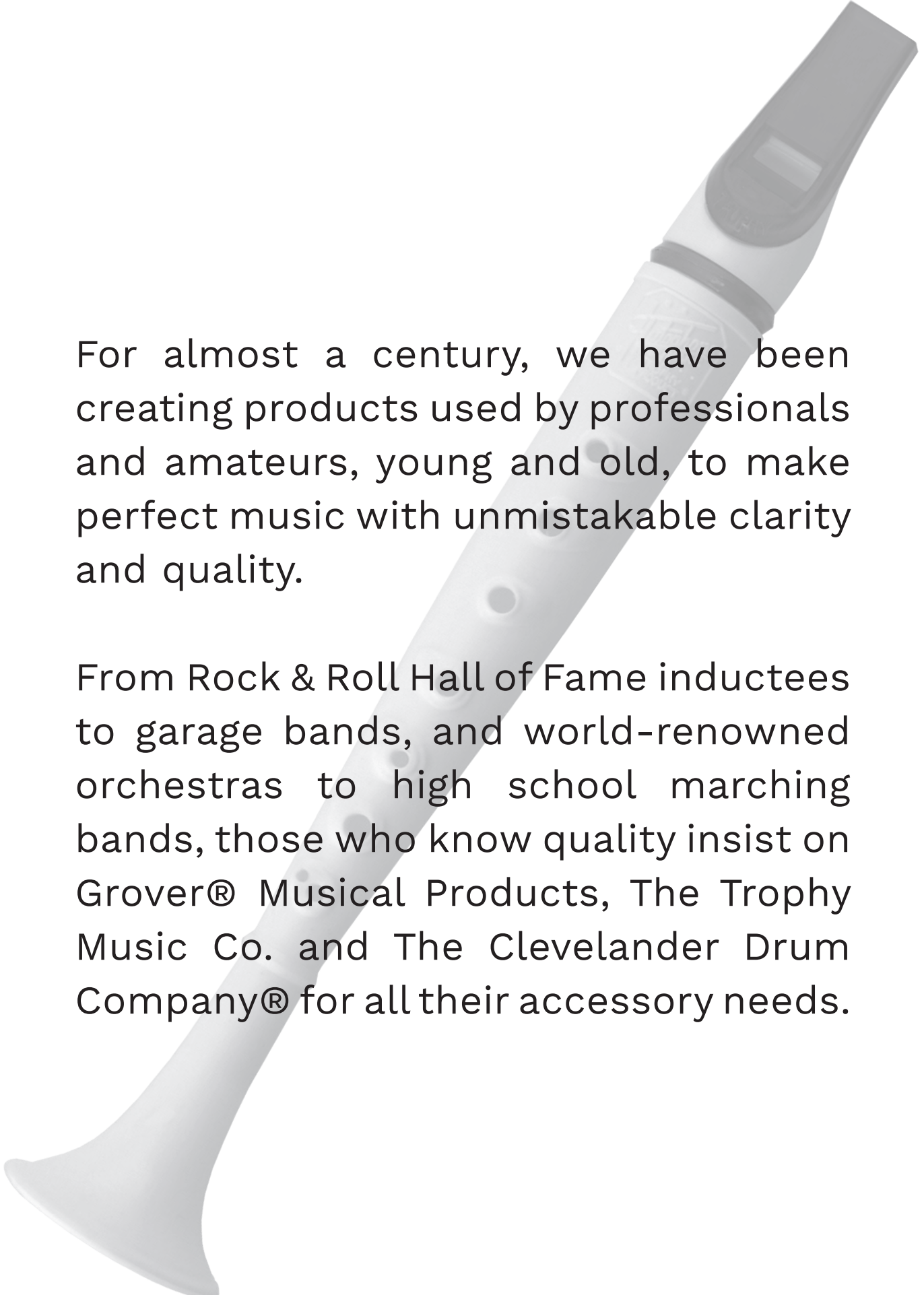

For almost a century, we have been creating products used by professionals and amateurs, young and old, to make perfect music with unmistakable clarity and quality.

From Rock & Roll Hall of Fame inductees to garage bands, and world-renowned orchestras to high school marching bands, those who know quality insist on Grover® Musical Products, The Trophy Music Co. and The Clevelander Drum Company® for all their accessory needs.



GROVER[®]
WORLD'S FINEST MACHINE HEADS

For over a century, Grover® has keeping the world's finest string instruments in tune. It started in the late 1800's when Grover first produced a few guitar and banjo machine heads, then expanded into additional production of tuners for bass guitar, pedal steel, mandolin, dulcimer, ukulele and violin.

While many changes have taken place over the years, the one constant has been that we continue to supply the music industry with the finest products available.

From the world's first enclosed, permanently lubricated machine heads, to our newest technological breakthroughs, we are proud to be original equipment on many of the world's finest string instruments.

Today, our expanded product line includes a wide assortment of guitar accessories for upgrading and repair and features several new items.

Since our production process utilizes only the top of the line quality standards, we proudly stand behind our machine heads with the following lifetime warranty... should your Grover tuners ever fail, for any reason, simply return them to us for a fast and friendly no charge repair or replacement.

If you are already using Grover products, thank you for your support in making Grover the most trusted name in music around the world. If not, maybe it's time to **"Change over to Grover!"**

Richard Berger,
CEO

FINISHES AND SPECIFICATIONS

FINISHES

Availability varies with each style. Check under individual product descriptions.



N Nickel



C Chrome



BN Black Nickel



BC Black Chrome



G Gold



POST HOLE SIZES

Many of the Grover tuners will fit the existing holes in the headstock without any modification at all. However, we realize sometimes the existing holes need to be enlarged a bit in order for our tuners to fit properly. As a result, we have provided the chart below showing the exact drill bit size needed for each tuner series. Please note, always enlarge the hole size from the front, or face, of the headstock.

Tuner Series	Hole Size
102	25/64"
106	25/64"
109	25/64"
115	21/64"
116	23/64"
117	21/64"
118	21/64"
119	3/8"
120	3/8"
121	3/8"
122	3/8"
123	3/8"
124	3/8"
133	23/64"
135	25/64"
136	25/64"
138	23/64"
142	45/64"

Tuner Series	Hole Size
144	35/64"
145	21/64"
150	25/64"
162	11/32"
163	11/32"
164	11/32"
205	25/64"
303	25/64"
304	23/64"
305	25/64"
306	25/64"
308	21/64"
406	25/64"
502	25/64"
505	25/64"
608	21/64"
708	15/64"
H97	15/64"
V97	23/64"

Tuner Series	Hole Size
H98	15/64"
V98	23/64"
870	5/16"
872	21/64"
885	21/64"
886	21/64"
887	21/64"
1	21/64"
2	21/64"
3	5/16"
4	5/16"
5	11/32"
8	23/64"
9	23/64"
25	11/32"
75	11/32"
85	11/32"
88	11/32"

GROVER® ROTOMATICS®

ORIGINAL ROTOMATICS® (102 SERIES)

These guitar machines are a triumph in engineering and styling. The housing provides a maximum bearing for worm, gear and string post. Gear ratio is 14:1. Worm and gear are precision-cut for perfect meshing. This eliminates backlash and slippage. Countersunk tension screw permits player to regulate turning tension to any degree. Gear box has a special lubricant for lifetime, trouble-free service. Includes 5/8" washers, bushings and wood screws.



For standard guitars, Set of 6

(102N Nickel), (102C Chrome), (102BN Black Nickel), (102BC Black Chrome), (102G Gold)



For standard guitars with KEYSTONE BUTTONS, Set of 6

(102NK Nickel), (102CK Chrome), (102GK Gold)



ROTOMATICS® WITH 18:1 GEAR RATIO (102-18 SERIES)

The original Rotomatic® with an improved higher ratio gearing. The 18:1 ratio provides for finer tuning and greater stability. The finer gears provide smoother tuning and a higher degree of backlash elimination. This new version of the Rotomatics® uses the exact housing as the original. Only the gearing has changed. Includes washers, bushings, and wood screws.



For standard guitars, Set of 6

(102-18N Nickel), (102-18C Chrome), (102-18BN Black Nickel), (102-18BC Black Chrome), (102-18G Gold)



For standard guitars with KEYSTONE BUTTONS, Set of 6

(102-18NK Nickel), (102-18CK Chrome), (102-18GK Gold)



ROTOMATICS®

ORIGINAL “Milk Bottle” STYLE ROTOMATICS® (102V SERIES)

The 102V series is a remake (replica) of the original “Milkbottle” style Rotomatics® first introduced by Grover®. With an improved 18:1 gear ratio, this unique style will make any vintage guitar appear truly original.



For standard guitars, Set of 6
(102NV Nickel), (102CV Chrome), (102GV Gold)



ORIGINAL “Milk Bottle” STYLE ROTOMATICS® w/ PEARLIOD BUTTON (103 SERIES)

This model offers the same specs and styling as the Original “Milk Bottle” style Rotomatics® 102V Series, but with Pearloid Buttons and button retainer. Gear Ratio of 18:1.



For standard guitars, Set of 6
(103C Chrome), (103G Gold)



SUPER ROTOMATICS® (109 SERIES)

The Super Rotomatic® has a 14:1 gear ratio. The 3 step button gives this machine a distinctive look and the sealed-in lubrication assures smooth gear-and-worm movement for the life of the machine.



3 Treble and 3 Bass, Set of 6
(109C Chrome), (109BC Black Chrome), (109G Gold)



SUPER ROTOMATICS® (109-18 SERIES)

The Super Rotomatic® now comes in a 18:1 gear ratio. The 3 step button gives this machine a distinctive look and the sealed-in lubrication assures smooth gear-and-worm movement for the life of the machine.



3 Treble and 3 Bass, Set of 6
(109C Chrome), (109BC Black Chrome), (109G Gold)



GROVER® ROTOMATICS®



MINI ROTOMATICS® (205 SERIES)

Totally professional in design and performance. Small, lightweight, this precision made machine fits guitar headpieces that will not take full size machines. The mini buttons provide more space for player's fingers (even large fingers) to tune strings. Gear ratio is 14:1. Sealed in lubrication keeps the mini perfect for a lifetime! Includes 5/8" washers, bushings and wood screws.

3 treble and 3 bass, Set of 6

(205C Chrome), (205BN Black Nickel), (205BC Black Chrome), (205G Gold)

6-in-line, Set of 6

(205C6 Chrome), (205BN6 Black Nickel), (205BC6 Black Chrome), (205G6 Gold)

Left-hand 6-in-line, Set of 6

(205CL6 Chrome), (205BNL6 Black Nickel), (205BCL6 Black Chrome), (205GL6 Gold)

12-string, Set of 12

(205C12 Chrome), (205BN12 Black Nickel), (205BC12 Black Chrome), (205G12 Gold)



MID-SIZE ROTOMATICS® (305 SERIES)

The Mid-Size series is made with the same quality as the other Rotomatic® models. Slightly larger than the Mini Rotomatics®, the mid size series features an 18:1 gear ratio for smoother, more precise tuning. This compact machine head is perfect for use on smaller and in-line headpieces.

3 treble and 3 bass, Set of 6

(305C Chrome), (305BC Black Chrome), (305G Gold)

6-in-line, Set of 6

(305C6 Chrome), (305BC6 Black Chrome), (305G6 Gold)

Left-hand 6-in-line, Set of 6

(305CL6 Chrome), (305BCL6 Black Chrome), (305GL6 Gold)

12-string, Set of 12

(305C12 Chrome), (305BC12 Black Chrome), (305G12 Gold)



LOCKING STRING INSTALLATION INSTRUCTIONS

Instructions for 106, 406

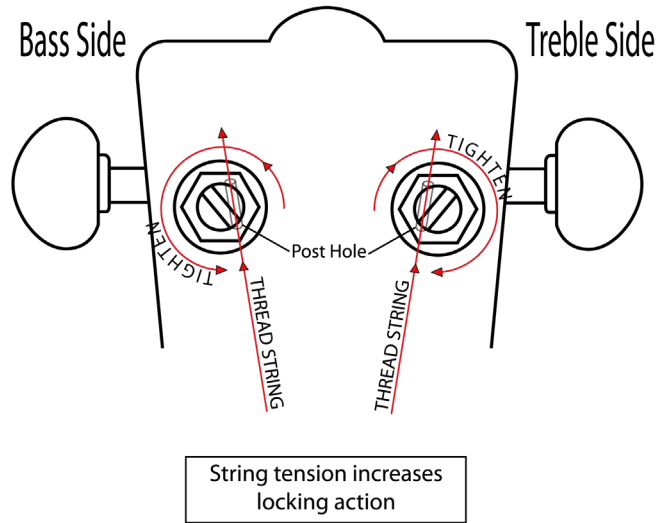

1. Turn tip of string post until it clicks into place. This aligns string post holes.
2. **Note string hole is off center.** Turn knob to rotate post until string hole is positioned away from knob. Thread string up through bottom of hole and pull firmly. **See drawing.**
3. Turn to begin tuning. **At first, only inner “Locking Cam” is turning, securely locking the string.** Once the string is locked, outer post will turn.
4. Bring string to pitch.

Instructions for 502, 505, 505FV, 533

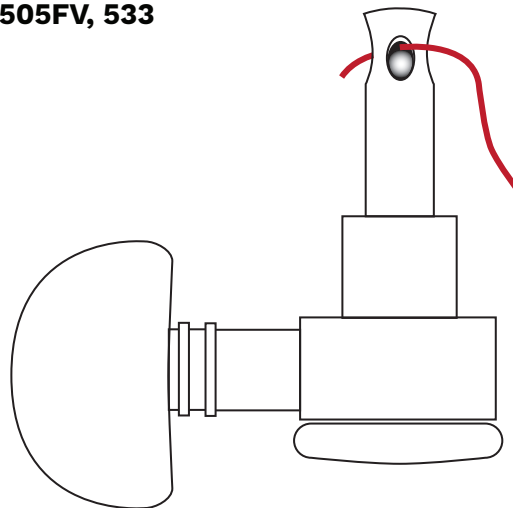

1. Turn thumbwheel counter clockwise until pin inside post hole cannot be seen.
2. Insert string through post hole and pull through, leaving enough slack for one rotation of post.
3. Turn thumbwheel clockwise until tight. Pin inside post hole has now locked the string.
4. Bring string to pitch.

LOCKING ROTOMATICS®

US PATENT NUMBER 6,078,001

Grover's patented locking tuners have eliminated the obstacles of other locking devices. Since there are no external mechanisms to initiate the locking action, the machine head's appearance is like any other. The entire locking mechanism is self-contained and Self-actuated.

ORIGINAL LOCKING ROTOMATICS® (106 SERIES)



The introduction of the new Grover Locking Rotomatics® give you the ease of use provided by a standard tuner and the positive locking of our internal cam post. Simply insert the string through the string hole, pull to tension by hand and begin tuning. As you start to tune, only the locking cam in the string post turns. Once the string is locked, the string post begins to turn allowing you to bring the string to pitch. In less than one revolution of the string post, you will be in tune, to stay in tune. Gear ratio is 18:1.

For standard guitars, Set of 6

(106C Chrome), (106BC Black Chrome), (106G Gold)



MINI LOCKING ROTOMATICS® (406 SERIES)



The same innovative engineering and classic design as the Original Locking Rotomatics®, but with smaller buttons for 6-in-line guitars, or for those who prefer a little more space for their fingers. Gear ratio is 18:1.

3 Treble and 3 Bass, Set of 6

(406C Chrome), (406BC Black Chrome), (406G Gold)

6-in-line, Set of 6

(406C6 Chrome), (406BC6 Black Chrome), (406G6 Gold)

Left-hand 6-in-line, Set of 6

(406CL6 Chrome), (406BCL6 Black Chrome), (406GL6 Gold)



ROTO-GRIP LOCKING ROTOMATICS® (502 SERIES)

Roto-Grip locking Rotomatics® utilize the famous 18:1 Rotomatic® design with a "thumb screw" mechanism which locks the string into place. Insert the string through the post hole, wrap around once, then lock by tightening with the thumb screw. Perfect replacement for the most standard machine heads. Includes all mounting hardware.

3 Treble and 3 Bass, Set of 6

(502N Nickel) (502C Chrome), (502BC Black Chrome), (502G Gold)



For standard guitars with KEYSTONE BUTTONS, Set of 6

(502NK Nickel), (502CK Chrome), (502GK Gold)



LOCKING ROTOMATICS®

ROTO-GRIP LOCKING SUPER ROTOMATICS® (509 SERIES)



The newest addition to the Grover family, these locking machine heads with a 3 step button gives this machine a distinctive look and utilizes the famous 18:1 Rotomatic® design with a “thumb screw” mechanism which locks the string into place. Insert the string through the post hole, wrap around once, then lock by tightening with the thumb screw. Perfect replacement for the most standard machine heads. Includes all mounting hardware.

3 Treble and 3 Bass, Set of 6

(509C Chrome), (509BC Black Chrome), (509G Gold)



MINI ROTO-GRIP LOCKING ROTOMATICS® (505 SERIES)



A smaller version of the regular size ROTO-GRIP® lockers for the in line and smaller headstocks or for those who prefer a lighter feel.

3 Treble and 3 Bass, Set of 6

(505C Chrome), (505BC Black Chrome), (505G Gold)

6-in-line, Set of 6

(505C6 Chrome), (505BC6 Black Chrome), (505G6 Gold)

Left-hand 6-in-line, Set of 6

(505CL6 Chrome), (505BCL6 Black Chrome), (505GL6 Gold)

12-string, Set of 12

(505C12 Chrome), (505BC12 Black Chrome), (505G12 Gold)



MINI ROTO-GRIP LOCKING ROTOMATICS® (505FV SERIES)



The 505FV series design allows you to upgrade your vintage Fender® tuners. Improved is the 18:1 gear ratio. along with a more modern style locking tuner without making ANY modifications to your guitar. The overlapping ear design allows you to utilize the existing screw holes and the use of push-in bushings, rather than screw-in, means no modifications have to be made to the post holes.

6-in-line, Set of 6

(505FVN Nickel), (505FVC Chrome), (505FVG Gold)



LOCKING VINTAGE

VINTAGE LOCKING (533 SERIES)

Mechanically engineered to the most precise standards of excellence, with the classic look of vintage styling, Grover's Vintage 533 locking series come with a "thumb screw" mechanism, which locks the string into place. Insert the string through the post hole, wrap around once, then lock by tightening with the thumb screw. Worm and gear are cut to mesh perfectly, thereby eliminating backlash and slippage. The housings are self-lubricating for a lifetime of trouble-free service. 15:1 gear ratio.



3 treble and 3 bass, Set of 6
(533N Nickel), (533G Gold)

6-in-line, Set of 6
(533N6 Nickel), (533G6 Gold)

For standard guitars with KEYSTONE BUTTONS, Set of 6
(533NK Nickel), (533GK Gold)

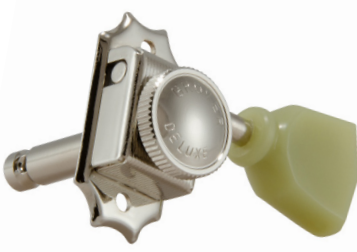



STA-TITE™ (97 SERIES)

The Original Grover® Sta-Tite™ machine head. The classic styling of the Sta-Tite™ returns with the Grover® name. The butter bean button identifies this as the original. A 14:1 gear ratio provides precise tuning. Available in Chrome, Gold or Nickel finish with horizontal or vertical string post in 3 + 3 configuration. Wood screws, washers, and bushings included.

Vertical, 3 Treble and 3 Bass, Set of 6
(V97N Nickel), (V97C Chrome), (V97G Gold)

Horizontal, 3 Treble and 3 Bass, Set of 6
(H97N Nickel), (H97C Chrome), (H97G Gold)



STA-TITE™ WITH 18:1 GEAR RATIO (97-18 SERIES)

The same excellent features as the original 97 Series, now with an 18:1 gear ratio!

Vertical, 3 Treble and 3 Bass, Set of 6
(V97-18NA Nickel), (V97-18GA Gold)

Horizontal, 3 Treble and 3 Bass, Set of 6
(H97-18NA Nickel), (H97-18GA Gold)

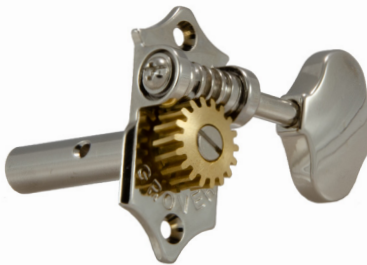
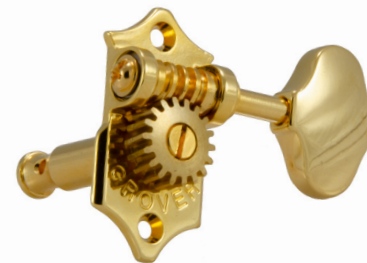

STA-TITE™ (98 SERIES)

Beautiful machine heads with the classic round button, the 98 Series provides smooth, sure tuning. Heavily plated finish with a striking contrast to the brass gears. Screws and bushing included.

Vertical, 3 Treble and 3 Bass, Set of 6
(V98N Nickel), (V98C Chrome)

Horizontal, 3 Treble and 3 Bass, Set of 6
(H98N Nickel), (H98C Chrome)





DELUXE GUITAR MACHINES (133 SERIES)

Mechanically engineered to the most precise standards of excellence, with the classic look of vintage styling, Grover Deluxe machine heads are a timeless achievement for guitar tuning. Worm and gear are cut to mesh perfectly, thereby eliminating backlash and slippage. The housings are self-lubricating for a lifetime of trouble-free service.

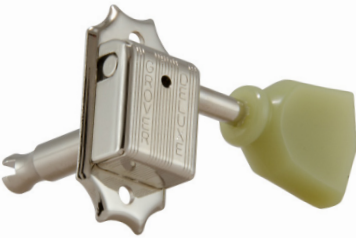

3 Treble and 3 Bass with safety post, Set of 6
(133N Nickel), (133GK Gold)

For standard guitars with KEYSTONE BUTTONS, Set of 6
(133NK Nickel), (133GK Gold)

6-in-line, Set of 6
(133N6 Nickel), (133G6 Gold)

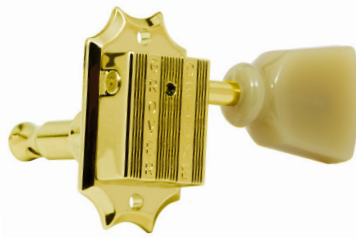

VINTAGE (135 SERIES)

Our new Vintage machine uses a die-cast, two-piece housing for additional strength and precision. The unique bearing surface in the housing provides a rigid string post enhancing the alignment of the gear and worm. The 14:1 gear ratio provides for fine tuning.

3 Treble and 3 Bass, Set of 6
(135N Nickel), (135G Gold)

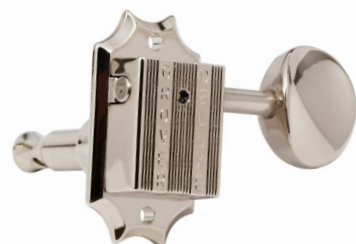

VINTAGE DELUXE (136 SERIES)

Like our Vintage machine heads, the 136 uses the same sturdy construction of our die-cast, two-piece housing. New for the 136 Series is the classic rounded button made popular in the 1950's. If you're going retro, the 136 Series is definitely for you!

3 Treble and 3 Bass, Set of 6
(136N Nickel), (136G Gold)

6-in-line bass side
(136N6 Nickel), (136G6 Gold)



VINTAGE (138 SERIES)

The Grover® deluxe machine heads are mounted three to a plate for the vintage look that has been popular for decades. The stamped back plate provides a sturdy base for mounting vertically or horizontally on the head stock. The housings are securely fastened to the base insuring proper gear and worm alignment for accurate tuning. Bushing and screws included.

Vertical, 3 Treble and 3 Bass, Set of 6
(V138N Nickel)

Horizontal, 3 Treble and 3 Bass, Set of 6
(H138N Nickel)



IMPERIAL™ (150 SERIES)

Distinctive in styling and quality, the Imperial™ made it's first appearance in the 1970's. The most notable feature of this unique machine head is the futuristic Three Step button, a fresh and funky design trademarked by Grover. This re-introduction of the Imperial™ is an exact reproduction of the originals, including a 16:1 gear ratio.

3 Treble and 3 Bass, Set of 6
(150C Chrome), (150G Gold)



STA-TITE™ MINI 3-ON-A-PLATE (608 SERIES)

For small headpiece that will not take full-size models. 18:1 gear ratio for extra fine tuning. Mounting hardware included.

(608N Nickel), (608G Gold)



BASS



VINTAGE BASS MACHINE HEADS (142 SERIES)

Precision and durability with classic styling make these bass machine heads ideal for manufacturing or upgrading instruments. The die cast housing is a sturdy foundation for maintaining center lines of the worm and gear. A fixed bearing surface in the housing creates a smooth tuning surface for easy tuning. The safety string post and “elephant ear” button provide utility and a vintage look. Available in 4-in-line or 2 + 2 configurations. Bushings and wood screws included.

2 Treble, 2 Bass
(142C Chrome)

4-in-line
(142C4 Chrome)



MINI BASS MACHINES (144 SERIES)

The Grover® “MINI” is lightweight, compact and durable for modern electric basses. Gear ratio is 20:1. Housing is specially machined to achieve the precise tolerance that prevents slippage and allows fine tuning. Sealed gear box has permanent lubrication that makes the MINI friction-free for life. Individually hand-tested. Screws and bushings included.

2 Treble, 2 Bass
(144C Chrome), (144BC Black Chrome), (144G Gold)

4-in-line
(144C4 Chrome), (144BC4 Black Chrome), (144G4 Gold)

Left hand models
(144CL4 Chrome), (144BCL4 Black Chrome), (144GL4 Gold)



TITAN® ELECTRIC BASS MACHINES (145 SERIES)

SELF ALIGNING THRUST BEARINGS! Gear ratio is 20:1. Special butterfly button. Durable cast housing. End thrust bearings. Worm meshes perfectly with gear. Safety-type string posts with cutaway shoulders to provide slip-over. Two screws in housing apron provide greater holding power. May be used with ALL modern bass guitar headpieces. Individually hand tested. Screws and bushings included.

2 Treble, 2 Bass
(145C Chrome), (145BC Black Chrome), (145G Gold)

4-in-line
(145C4 Chrome), (145BC4 Black Chrome), (145G4 Gold)

Left hand models
(145CL4 Chrome), (145BCL4 Black Chrome), (145GL4 Gold)



PEDAL STEEL & CLASSIC GUITAR

PEDAL STEEL GUITAR MACHINES (210 SERIES)



This model is designed specifically for use with pedal steels. The shortened string post and bushing are designed for the slotted head of a pedal steel. It will accommodate a headstock thickness varying from .235" (5.97mm) to .400" (10.16mm). The string post extends .900" (22.87mm) from the base of the housing. The new housing has a mounting pin at the back, eliminating the need for a mounting screw. This also facilitates mounting on the cast headstocks used on pedal steel guitars.

Set of 10
(210C Chrome)



CLASSIC GUITAR MACHINES (303 SERIES)



Traditional Grover® quality and craftsmanship. Beautifully engraved plates. Three on a plate. Butterfly style, pearloid buttons, plastic coated string posts. Includes screws.

3 + 3, Set of 6
(303N Nickel), (303G Gold)



DELUXE CLASSIC MACHINE HEADS (306 SERIES)



Excellence in materials and craftsmanship are the hallmark features of these classic machine heads. The die cast base provides a rigid foundation for the gear and worm, assuring perfect alignment and mesh. The pearloid buttons are attached with a tension screw to provide the feel of your preference. A bearing over the worm shaft provides additional support and enhances the smooth performance. Includes wood screws.

3 + 3, Set of 6
(306N Nickel), (306G Gold)



MANDOLIN



STA-TITE™ MANDOLIN MACHINES (304 SERIES)

Precise engineering assures sure, smooth tuning. One piece back plates. Brass gears mean perfect meshing. Heavily plated. Screws and bushings included.

Standard 4 + 4, Set of 8

(304C Chrome), (304G Gold)



Standard "A" Style

PROFESSIONAL MANDOLIN MACHINE HEADS (409 SERIES)

These new, professional model mandolin machine heads are the latest in technology. A specially designed, adjustable worm gear along with the die cast base maintains the center lines of the gear and worm to insure correct alignment for the finest tuning possible. Now featuring a "rounded washer head" button screw for a more vintage style. The worm to gear ratio is 18:1. Available in "A", "F", and "F Vintage" styles with our new either Pearloid, Black or White buttons. Screws and bushing provided.

Standard 4 + 4, For "A" style Mandolins with Pearloid Buttons

(409N Nickel), (409G Gold)



Standard "F" Style

Standard 4 + 4, For "F" style Mandolins with Pearloid Buttons

(409FN Nickel), (409FG Gold)

Vintage 4 + 4, For "F" style Mandolins with Pearloid Buttons

(409FVN Nickel), (409FVG Gold)

Standard 4 + 4, For "A" style Mandolins with Black Buttons

(409NB Nickel), (409GB Gold)

Standard 4 + 4, For "F" style Mandolins with Black Buttons

(409FNB Nickel), (409FGB Gold)

Vintage 4 + 4, For "F" style Mandolins with Black Buttons

(409FVNB Nickel), (409FVGB Gold)

Standard 4 + 4, For "A" style Mandolins with White Buttons

(409NW Nickel), (409GW Gold)



Vintage "F" Style

Standard 4 + 4, For "F" style Mandolins with White Buttons

(409FNW Nickel), (409FGW Gold)

Vintage 4 + 4, For "F" style Mandolins with White Buttons

(409FVNW Nickel), (409FVGW Gold)



BANJO

GEARED BANJO PEGS (SET OF 4)



Metal Buttons
(119N Nickel), (119C Chrome), (119G Gold)

Square Pearloid Buttons
(120N Nickel), (120C Chrome), (120G Gold)

Round Pearloid Buttons
(123N Nickel), (123C Chrome), (123G Gold),



GEARED BANJO PEGS (SET OF 5)



Metal Buttons
(121N5 Nickel), (121C5 Chrome), (121G5 Gold)

Square Pearloid Buttons
(122N5 Nickel), (122C5 Chrome), (122G5 Gold)

Round Pearloid Buttons
(124N5 Nickel), (124C5 Chrome), (124G5 Gold)



GEARED BANJO 5th PEG



Metal Buttons
(162N Nickel), (162C Chrome), (162G Gold)

Square Pearloid Buttons
(163N Nickel), (163C Chrome), (163G Gold)

Round Pearloid Buttons
(164N Nickel), (164C Chrome), (164G Gold)



BANJO

PERMA TENSION™ TENOR BANJO PEGS (SET OF 4)



Metal Buttons
(115N Nickel)

Square Pearloid Buttons
(885N Nickel)



PERMA TENSION™ BANJO PEGS (SET OF 5)

No slippage, no backlash, no looseness, Heavy knurled bushings with threaded extension, locks permanently into wood. Countersunk button screw regulates tension.



Metal Buttons
(117N Nickel)

Square Pearloid Buttons
(886N Nickel)



PERMA TENSION™ BANJO 5TH PEG



Metal Button
(118N Nickel), (118C Chrome)

Square Pearloid Button
(887N Nickel), (887C Chrome)

Black Button
(872N Nickel)



CHAMPION™ BANJO PEGS

Favorite, popular-priced patented peg for nearly three generations. Positive, non-slip action will last a lifetime. Non-breakable black buttons.



Black Buttons, Set of 5
(25B Nickel)

Black Buttons, Set of 4
(75B Nickel)



BANJO 5th STRING PEG

A traditional style peg with a knurled brass insert and a nickel-plated pressure sleeve.



Ivory Button
(116N Nickel)





STA-TITE™ U98 SERIES GEARED UKULELE PEGS

The Original Grover® Sta-Tite™ machine heads are now available for Ukuleles with an 18:1 gear ratio for precise tuning, still with the classic styling and butter bean button of the original Grover® Sta-Tite™ machine heads. The new U98-18N comes with a .994” (25.2mm) long post. Heavily nickel plated. Set of four includes bushings and wood screws.

Metal Buttons
(U98-18N Nickel)



STA-TITE™ U99 SERIES GEARED UKULELE PEGS

The Original Grover® Sta-Tite™ machine heads are now available for Ukuleles with an 18:1 gear ratio for precise tuning, still with the classic styling and butter bean button of the original Grover® Sta-Tite™ machine heads. The new U99-18N comes with a .827” (21mm) long post. Heavily nickel plated. Set of four includes bushings and wood screws.

Metal Buttons
(U99-18N Nickel)



STA-TITE™ #8 SERIES GEARED UKULELE PEGS

The one-piece back plate, brass gear, die cast button and knurled bushings are the same as those used on the Sta-Tite™ guitar machine head. The string post has been shortened to one inch with the string hole .775” from the back of the base. 14:1 gear ratio provides for accurate tuning. Heavily nickel plated. Set of four includes bushings and wood screws.

Metal Buttons
(8N Nickel), (8G Gold)



STA-TITE™ #9 SERIES GEARED UKULELE PEGS

The #9 series has the same features, but with a shorter string post with the string hole .630” from the back of the base. The gear ratio is 14:1. Available in nickel and gold with black or white buttons and each set includes all mounting hardware.

(9NB Nickel/Black Buttons), (9NW Nickel/White Buttons)

(9GB Gold/Black Buttons), (9GW Gold/White Buttons)



UKULELE, BARITONE UKULELE/TENOR GUITAR



CHAMPION™ DELUXE UKULELE PEG

Nickel plated ukulele pegs used on the finest quality ukuleles. Special “thumb screw” for tension adjustment. Knurled, pressure fit parts for smooth tuning.

Pearloid Button

(1W Nickel/White Button)



CHAMPION™ PEGS (SET OF 4)

Favorite, popular-priced patented peg for nearly three generations. Positive, non-slip action will last a lifetime. Non-breakable black buttons.

(85B Nickel/Black Buttons)



(2B Nickel/Black Buttons), **(2W** Nickel/White Buttons)



(3B Nickel/Black Buttons), **(3W** Nickel/White Buttons)



CHAMPION™ BARITONE UKULELE OR TENOR GUITAR PEGS (SET OF 4)

Favorite, popular-priced patented peg for nearly three generations. Positive, non-slip action will last a lifetime. Non-breakable black buttons.

(88B Nickel)



DULCIMER & VIOLIN PEGS

STA-TITE™ DULCIMER PEGS (SET OF 4)

The ideal peg for Dulcimer or Banjo. Metal shank with two knurled bushings that will press tightly into a 5/16” headpiece hole. Has special patented retainer and will fit any Dulcimer or Banjo headpiece, 7/16” to 5/8” thick. Patent # 206, 406.



(870 Nickel/Black Plastic Buttons)



(870BR Nickel/Rosewood Buttons)



STA-TITE™ DULCIMER PEGS (SET OF 4)

These individual tuners have a special post with dual staggered post holes made for Mandolins. The overall post length is 1.25” with the center of one hole at .56” and the center of the second hole at .86” from the bottom of the base. Available in nickel and gold, complete with all mounting hardware.

(708N Nickel), (708G Gold)



CHAMPION™ VIOLIN PEGS (SET OF 4)

Favorite, popular-priced patented peg for nearly three generations. Positive, non-slip action will last a lifetime. Non-breakable black buttons.



(5B Nickel)



GUITAR BRIDGES



PIN STYLE GUITAR BRIDGE

Rosewood glue-on or screw-on style guitar bridge. Holes for bridge pins.

(3343) White plastic saddle or fret



PINLESS TYPE GUITAR BRIDGE

Rosewood glue-on or screw-on style guitar bridge. Great for classical or flamenco-style guitars.

(3344) Plastic saddle or fret



BRIDGES FOR 12-STRING GUITAR

Rosewood glue-on or screw-on style guitar bridge. Classic 7" wide fan-shape design for 12-string guitars.

(3378) White plastic saddle



ADJUSTABLE BRIDGES

Two piece rosewood bridge. Adjustable style. 6" wide. For 6 or 12-string guitars with a tailpiece.

(3379) Metal saddle



BRIDGES FOR ARCHTOP GUITARS

Two piece bridge. Fully adjustable 11/16" to 15/16" for archtop guitars.

(7919) Hardwood, Ebonized



(7926) Rosewood

MANDOLIN BRIDGES



TUNE-KRAFT™ MANDOLIN BRIDGE

Classic genuine rosewood bridge for flat top style mandolins.

(1990 Rosewood)



TUNE-KRAFT™ MANDOLIN BRIDGE

Polished ebony bridge with bone inlay for flat top mandolins. Precision-marked string inserts.

(1991 Ebony)



ACOUSTICRAFT™ MANDOLIN BRIDGES

Polished ebony two-piece mandolin bridge. Fully adjustable for archtop mandolins. The height can also be adjusted to compensate for suspended fingerboards.

(1992 Ebony)

BANJO BRIDGES and ACCESSORIES



LEADER™ BANJO BRIDGES

Made of select hard maple with ebony top. Specify height when ordering.

- (30.H** Tenor banjo, 1/2" high)
- (30.5/8** Tenor banjo, 5/8" high)
- (30B.H** 5-string banjo, 1/2" high)
- (30B.5/8** 5-string banjo, 5/8" high)



MINSTREL™ BANJO BRIDGES

Popular 3-legged model. Select maple with ebony strip.

- (70** Tenor banjo, 1/2" high)
- (71** Tenor banjo, 5/8" high)
- (72** 5-string banjo, 1/2" high)
- (73** 5-string banjo, 5/8" high)



TUNE-KRAFT™ COMPENSATING BANJO BRIDGES

Made of select maple with specially shaped compensating ebony top. Gives each string its proper scale. Players can change keys without having to adjust their tuning.

- (76** 5-string banjo, 1/2" high)
- (77** 5-string banjo, 5/8" high)



ACOUSTICRAFT™ BANJO BRIDGES

Specially designed 3-legged bridges. Seasoned maple with ebony insert and individual ivoroid block.

- (90** Tenor banjo, 1/2" high)
- (91** Tenor banjo, 5/8" high),
- 95** 5-string banjo, 1/2" high)
- (96** 5-string banjo, 5/8" high)



DUAL BANJO BRACKET WRENCH

Dual Banjo Bracket Wrench, for installing and tightening banjo heads. Both popular sizes are affixed to one key. 1/4" size for all Gibson models and 5/16" size for many other makes.

No. GP195 Dual Banjo Bracket Wrench

GROVER®

CABLES



GROVER CABLES LIFETIME WARRANTY

Our cables are both assembled and equipped to meet the highest quality standards possible, allowing Grover to offer a lifetime warranty. Should your Grover cables ever fail, for any reason, simply return them to us for a fast and friendly no charge repair or replacement.

GROVER NOISELESS GUITAR/INSTRUMENT CABLES

A 6.5mm noiseless cable equipped with 1/4" straight molded phone plug ends. Specifically designed cables prevent shocks and allows for minimum hum or noise. Provides 100% signal.



- No. GP310** 10' cable-Black cable with Nickel plated 'Grover' engraved plugs
- No. GP320** 20' cable-Black cable with Nickel plated 'Grover' engraved plugs
- No. GP210** 10' cable-Braided fabric covered cable with Gold plated plugs
- No. GP220** 20' cable-Braided fabric covered cable with Gold plated plugs

GROVER MICROPHONE CABLE

A 6.5mm 2P braided microphone cable. Specifically designed to prevent shocks and allows for minimum hum or noise. Provides 100% signal



- No. GP425** 25' cable-XLR Female to 1/4" phone plug, High Z
- No. GP525** 25' cable-XLR Female to XLR Male, Low Z

GROVER SPEAKER CABLES

Equipped with a 1/4" nickel plated straight phone plug. Specifically designed cables prevent shocks and allows for minimum hum or noise providing 100% signal.



- No. GP620** 20' cable-Black cable with Nickel plated plugs
- No. GP630** 30' cable-Black cable with Nickel plated plugs

ACCESSORIES

ARTIST STRAP BUTTONS



These new buttons offer players the opportunity to attach their strap with style. They keep the players' strap locked without the hassles or expense of traditional strap locks. The two-piece screw on design let's the player change styles easily while the oversized die-cast buttons and custom-fitted o-rings safely secures the strap.

All hardware is provided and the installation process is simple. Replaces original strap button with no modification or damage to instrument.



- Skull** No. **GP610C** Chrome, No. **GP610G** Gold
- Eagle** No. **GP620C** Chrome, No. **GP620G** Gold
- Star** No. **GP630C** Chrome, No. **GP630G** Gold
- Iron Cross** No. **GP640C** Chrome, No. **GP640G** Gold

STRAP LOCKS



Grover Strap Locks feature the "quick release" mechanism players want and need. This strong, yet lightweight accessory provides security along with the ability to easily remove the strap for use on another instrument or storage. Available in Nickel, Chrome, Gold and Black finishes.

- No. **GP800N** Nickel
- No. **GP800G** Gold
- No. **GP800B** Black
- No. **GP800C** Chrome

REPLACEMENT STRAP LOCK END PINS



These extra end pins can be mounted on all guitars making it possible to use just one strap! Smooth, polished parts will not damage or mark up strap. Pack of two.

- No. **GP810N** Nickel
- No. **GP810G** Gold
- No. **GP810C** Chrome
- No. **GP810B** Black

GROVER GUITAR HUMIDIFIER



Protect your investment! It is essential to maintain a proper moisture level if your guitar is stored in an area prone to severe dryness and/or cold (such as a heated home). Our new guitar case humidifier helps to prevent adverse effects such as bad string action, buzzing, protruding fret ends, cracking, top-sinking, and other damage caused as a result of dryness. Made of soft latex which is harmless to all instrument finishes, these humidifiers release moisture to maintain proper humidity levels. Includes a cover to seal the sound hole during use. Easy-to-follow instructions and a user-friendly humidity gauge are included.

- No. **GP760** Guitar Humidifier

ULTRA CAPO

The Grover® Ultra Capo™ features the “World’s first” offset design which allows more room for the thumb on the back of the neck. Easy on... easy off... easy to position, the Ultra Capo™ also features a unique, non-glare matte finish for a soft, no-slip grip. Made of lightweight aluminum, The Ultra Capo™ has the quality you can expect from Grover® and the famous limited lifetime warranty. (Please note: rubber parts may naturally wear out over time and are not part of our lifetime warranty.)

**Available in:****No. GP750BL** Matte Black**No. GP750RD** Matte Red**No. GP750SL** Matte Silver**PERFECT NUT**

Sold successfully for over 50 years under the “Micro” brand, the new Grover® model is produced using a totally new, but exact reproduction die cast mold, which provides a much brighter, resonant sound than stamped steel versions.

1 7/8” total length – 1 5/8” Center E to Center E, The Grover® Perfect Nut will fit almost all six string guitars.

No. GP1103 Perfect Nut

GROVER®

ACCESSORIES

TREMOLO BRIDGE

This all purpose Tremolo is a perfect replacement for most guitars. Complete with adjustable saddles and all necessary mounting equipment, this affordable bridge is easily installed.

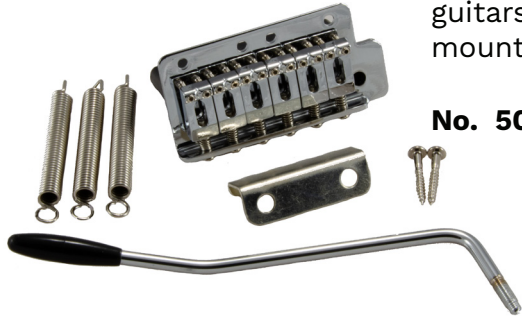

No. 500C Chrome

GUITAR BRIDGE (NOTCHED)

The Grover Tune-O-Matic style bridge is a direct original equipment replacement for all guitars utilizing this type. The saddle can be individually adjusted with the simple turn of a screw. Each bridge comes with two inserts and two thumbwheels for mounting and adjusting.



No. 520N Nickel **No. 520BN** Black Nickel
No. 520BC Black Chrome **No. 520G** Gold
No. 520C Chrome **No. 520CS** Chrome Satin

GUITAR BRIDGE (UNNOTCHED)

The Grover Tune-O-Matic style bridge is a direct original equipment replacement for all guitars utilizing this type. The saddle can be individually adjusted with the simple turn of a screw. Each bridge comes with two inserts and two thumbwheels for mounting and adjusting.



No. 521N Nickel **No. 521BN** Black Nickel
No. 521BC Black Chrome **No. 521G** Gold
No. 521C Chrome **No. 521CS** Chrome Satin

STOP TAILPIECE

Our Stop Tailpiece is made with two, set screws for additional adjustment. It comes complete with two studs and anchors for mounting. The stud spacing is 3 ¾", which is standard on most guitars.



No. 510C Chrome

TRUSS ROD WRENCHES

Truss Rods allow the curvature of the neck to be adjusted due to the natural "bows" or "warps" caused by string tension. Grover Truss Rod Adjusting Tools are made to fit the two most widely used truss rod sizes; 1/4 " and 5/16". This item is an indispensable tool for all players.



No. GP140 – 1/4" size
No. GP150 – 5/16" size

PARTS TRAYS •

No. GP172 Bridge Pin/End Pin Assortment (was 3310). 368 assorted bridge and end pins. Virtually every color combination contained to take care of any repair job.



Plastic Bridge Pins

- No. 3330** Black
- No. 3331** White
- No. 3331V** Ivory
- No. 3330D** Black w/ Dot
- No. 3331D** White w/ Dot
- No. 3331DV** Ivory w/ Dot

Plastic End Pins

- No. 3334** Black
- No. 3335** White
- No. 3334S** Black w/ Screw
- No. 3335S** White w/ Screw

GROVER SADDLE ASSORTMENT

No. GP173 Saddle Assortment (was 3373). Contains 24 each of the 6 most commonly used sizes (144 pcs. total). Very good quality.



Saddle Refills

- No. 3401** 2 1/2" x 1/4" Oval
- No. 3402** 2 1/2" x 3/8" Oval
- No. 3403** 3 1/4" x 1/4" Flat
- No. 3404** 3 1/4" x 5/16" Flat
- No. 3405** 3 1/4" x 3/8" Flat
- No. 3406** 3 1/4" x 7/16" Flat

GROVER NUT ASSORTMENT

No. GP170 Nut (was 3321). Assortment 114 of the most commonly used sizes. Quantities are adjusted according to popularity. Shaped and fitted.



Nut Refills

- No. 3301** 2"
- No. 3302** 1 7/8"
- No. 3303** 1 3/4"
- No. 3304** 1 5/8"
- No. 3306** 2" 12 string
- No. 3307** 1 5/8" Bass Guitar
- No. 3308** 1 1/8" Banjo

German Made Bridge Saddles
(Best Quality)



- No. 3340** 3 1/4" x 1/4" Flat
- No. 3341** 3 1/4" x 3/8" Oval

EBONY BRIDGE AND END PINS



Ebony Bridge Pins

- No. 3332** Ebony
- No. 3333** Ebony with Pearl Eye

Ebony End Pins

- No. 3336** Ebony
- No. 3337** Ebony with Pearl Eye

TROPHY Music Co.

Serving a diverse market, Trophy's musical, educational and novelty products such as the Flutophone®, Tudor® recorders, Flip Folders and FirstNote® items define the industry quality standard, along with a complete line of accessories.

TROPHY

WIND INSTRUMENTS

TUDOR® RECORDERS

Tudor® recorders have been used to introduce millions of children to the wonderful world of music! Accepted and requested by school systems everywhere!!



TD775



TD375



TD275



TD205



TD185



**TD175W
TD176W**



TD175



TD170

WIND INSTRUMENTS**TUDOR® RECORDERS**

From Soprano to Bass, in German or Baroque fingering, all Tudor® recorders are accurately tuned to A-440. Made of quality high-impact plastic. All instruments come complete with fingering chart, cleaning rod PLUS carrying pouch. Alto, Tenor and Bass instruments come with cases.

TD170 - SOPRANINO

Key of F. 3-piece instrument. Brown and white.

TD175 - SOPRANO

Key of C. 1-piece instrument. All brown.

TD175W - SOPRANO

Same as TD175 only in an ivory color.

TD176W - SOPRANO

Same as TD175W only German fingering.

TD185 - SOPRANO

Key of C. 2-piece instrument. Brown and white.

TD205 - SOPRANO

Key of C. Renaissance model. Classic 2-piece style, natural color.

TD275 - ALTO

Key of F. 3-piece instrument. Brown and white.

TD375 - TENOR

Key of C. Single key on bell section. Brown and white.

TD775 - BASS

Key of F. Double key on bell section and two single keys on the body section.

TROPHY

WIND INSTRUMENTS

CANDY APPLE by TUDOR®

FIVE “DELICIOUS” COLORS! All new from Tudor®... the #1 in school recorders throughout the country. These transparent recorders not only provide eye-candy, but sound great, too! All recorders come with easy-zipper pouch.



Fingering Chart on back of Pouch!

- No. **TD180RD** Red Recorder
- No. **TD180GR** Green Recorder
- No. **TD180BL** Blue Recorder
- No. **TD180GD** Gold Recorder
- No. **TD180PR** Purple Recorder



TROPHY

WIND INSTRUMENTS

1STNOTE® RECORDERS

Our new brightly colored FIRSTNOTE® recorders are high quality, precisely tuned and perfectly suitable for school music programs.

(Many inexpensive recorders sold today are not accepted by music teachers due to tone and pitch problems....Not FIRSTNOTE®...they play beautifully!)

Each recorder is packaged in a unique and durable drawstring bag and includes a cleaning rod and fingering chart.

No. FN60CR Cherry

No. FN60BA Banana

No. FN60SA Sour Apple

No. FN60BL Blueberry

No. FN60GR Grape

No. FN60BG Bubble Gum

No. FN60CH Chocolate

No. FN60LI Licorice



Cherry! **Sour Apple!** **Grape!** **Chocolate!**
Banana! **Blueberry!** **Bubble Gum!** **Licorice!**

TROPHY

WIND INSTRUMENTS

CAMBRIDGE® RECORDERS

The Cambridge is a more advanced 3-piece recorder. (The three pieces allow the instrument to be adjusted to play in tune with other instruments.) As outstanding value with great tone and is extremely durable. Complete with carrying bag and finger chart. Available in Dark Brown and Ivory.

No. 575 Dark Brown

No. 577 Ivory



FLUTOPHONE®

Over 50 million Flutophones have been sold since first introduced in 1945. The Flutophone is the easiest to play of all wind instruments and is used in thousands of classrooms across the country. Available in black and white.

No. 400 White

No. 401 Black





*Flutophone
Orchestra 1960's*

TROPHY

FLUTOPHONE® • RECORDERS MUSIC BOOKS

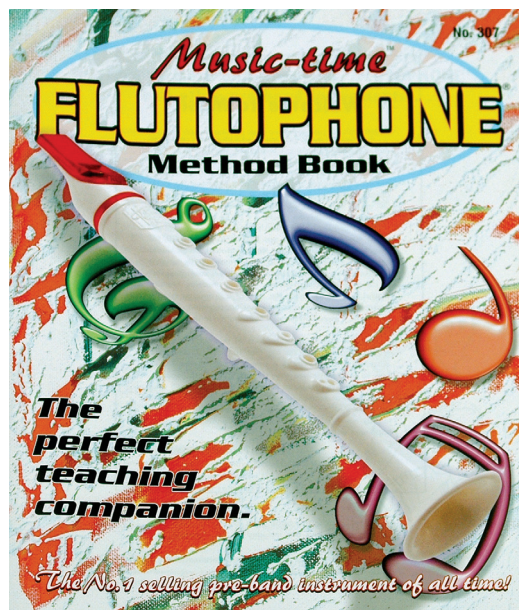
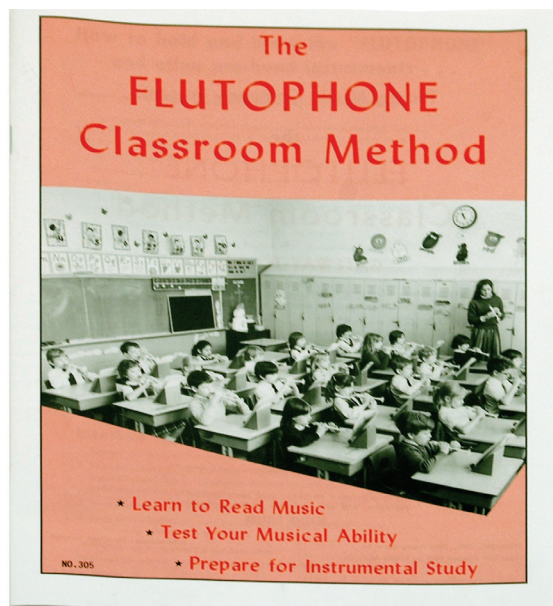

“Classroom” Method

The Flutophone Classroom Method is a 24-page, one octave size book, answering the need in elementary music education for a well-rounded instrumental and song-reading teaching technique.

No. 305

“Music-Time” Method

Great For Classroom Teachers Who Haven't Majored In Music A basic approach to teaching the Flutophone and other pre-band instruments. MUSIC-TIME provides an easier way to give youngsters a solid musical foundation.

No. 307



Elementary Recorder Book

Recommended By Leading Music Educators. Provides an easier approach to a thorough musical foundation - with more classroom interest. EVERY music educator should try this book. Music fundamentals and recorder playing progress in easy, natural steps in fingering and note study, which lead quickly to solo, duet and trio playing. The greater use of melodic material creates more fun for student and teacher. For all BAROQUE AND GERMAN RECORDERS.

No. 475 FOR ALL “C” RECORDERS

TROPHY

WIND INSTRUMENTS

IRISH WHISTLES

The Feadog pronounced fa dÓg (Gaelic for whistle) is the best available genuine Irish Penny Whistle imported from Dublin. Choose from F36 (36 in a counter display) available in brass only, F10 (individually packaged in a clear presentation tube) is available in the following colors: brass, red, green, blue and black, F15 (Hanger display with instruction booklet) available in brass only or F20 (Hanger display with instruction booklet and accompanying CD) available in brass only. All are supplied with fingering charts.

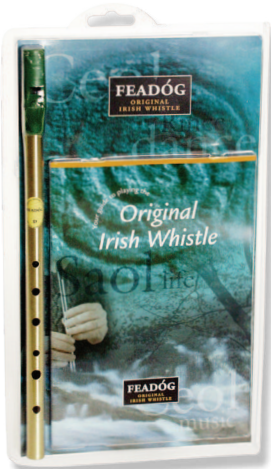

Hanger Display with Booklet
No. F15



Hanger Display with Booklet and CD
No. F20



- No. F10** Brass
- No. F10G** Green
- No. F10B** Blue
- No. F10BK** Black
- No. F10R** Red



Feadog counter display comes with 36 brass Irish Penny Whistles. Mouthpieces are individually wrapped for safety.
No. F36 Counter Display

TROPHY

FLUTOPHONE® • RECORDERS • WIND INSTRUMENT ACCESSORIES

CARRYING BAGS FOR FLUTOPHONE® AND RECORDERS



Deluxe Nylon® case with zipper for Flutophones.

No. 303D Flutophone®



Deluxe Vinyl case with zipper for Recorders.

(Fits all Soprano models)

No. 304D Recorders

FLUTOPHONE® AND RECORDERS ACCESSORIES

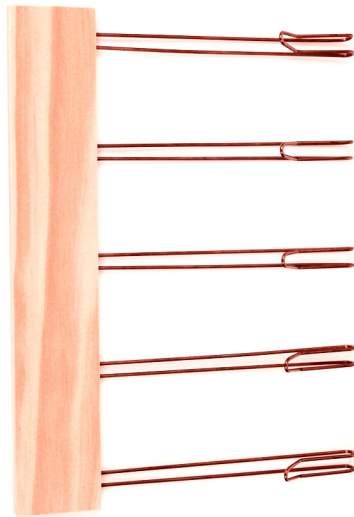

Staffboard Liner

Draws musical staff on blackboards.

No. 9100 Staffboard Liner



Music Desk Stand for Flutophone® and Recorder.

Strong pressboard. Folds flat so it is easy to store or carry to and from school.

No. 306 Music desk stand

Plastic Cleaning Rod

No. 8495 For recorder



HARMONICA HOLDER

Fits the neck comfortably. Large wing nuts make adjustment fast and easy. Springs hold the harmonica firmly in place after player positions the harmonica to his own playing preference providing greater individual control. Holds harmonicas up to 6-1/2" long. Comes in poly bag with header.

No. 2300 Harmonica Holder



TROPHY

FUN and EDUCATIONAL

1STNOTE® Mel-O-Dee Balls™



A fun and easy way to introduce children to music at home or in the classroom! Mel-O-Dee Balls™ are an accurately tuned, C to C, 8 ball set, individually colored and note marked, so that virtually anyone can learn to play. Each set contains sound-to-color music, with songs familiar to everyone. Mel-O-Dee Balls™ come packaged in a colorful display carton. Rated for 3+.

No. MB-8 Mel-O-Dee Balls

TROPHY

FUN and EDUCATIONAL RHYTHM KITS

All products are of excellent quality, in-tune and an exceptional value. Perfect for school use.

ECONOMY KITS

Item#	Description	TR21	TR22	TR23
		15 Players	25 Players	35 Players
A.	4854 8" Tambourine	-	-	-
B.	4982 6" Tom Boy w/Mallet	-	-	-
C.	4981 6" Snare Boy w/Mallet	-	-	-
D.	4980 5"x 5" Tom Tom w/Mallet	-	-	-
E.	4966 Sand Blocks	2	2	3
F.	4965 Tap Tap	2	4	4
G.	3704 7" Cymbals w/ Handles-pair	-	-	-
H.	4969 Handle Castanet	-	-	-
I.	3073 4 Bell Wrist Bells	2	4	5
J.	3566 3 Bell Cluster Bells	-	-	-
K.	FN250 Maracas	-	-	-
L.	3702 5" Cymbal w/ Mallet	1	2	2
M.	3456 Round Tone Block w/ Mallet	1	1	2
N.	3275 Quiro Tone Block	-	-	1
O.	3505 5" Triangle w/ Striker	1	2	2
P.	3201 Jingle Taps	4	6	8
Q.	3277 Rhythm Sticks-pair	2	4	8

DELUXE KITS

Item#	Description	TR45DLX	TR46DLX	TR47DLX
		15 Players	25 Players	35 Players
A.	4854 8" Tambourine	2	2	2
B.	4982 6" Tom Boy w/Mallet	-	1	-
C.	4981 6" Snare Boy w/Mallet	1	1	2
D.	4980 5"x 5" Tom Tom w/Mallet	1	1	2
E.	4966 Sand Blocks	1	2	2
F.	4965 Tap Tap	1	2	4
G.	3704 7" Cymbals w/ Handles-pair	-	-	1
H.	4969 Handle Castanet	1	2	2
I.	3073 4 Bell Wrist Bells	1	4	4
J.	3566 3 Bell Cluster Bells	-	-	1
K.	FN250 Maracas	-	-	1
L.	3702 5" Cymbal w/ Mallet	1	1	1
M.	3456 Round Tone Block w/ Mallet	1	1	1
N.	3275 Quiro Tone Block	-	1	1
O.	3505 5" Triangle w/ Striker	2	2	3
P.	3201 Jingle Taps	2	2	3
Q.	3277 Rhythm Sticks-pair	1	3	4

Kits include instruments shown in chart plus a convenient storage container. (Kit-TR21 includes a corrugated carrying case w/ handle.)

Kits include instruments shown in chart plus a convenient storage container.

This page contains a selection of percussion instruments most often used in elementary school music programs. All products are safe, high quality and widely accepted by music educators. All items are available individually or in very handy storage containers. Specially selected for group play. Individual products are bulk packed.



PERFECT FOR SCHOOL PROGRAMS!

Kits include instruments shown in chart plus a convenient storage container. (Kit-TR21 includes a corrugated carrying case w/handle.)



TROPHY

FUN and EDUCATIONAL RHYTHM KITS

MUSIC THERAPY KIT



Designed for Musical Therapists by a Musical Therapist. Trophy's new Musical Therapy Kit contains items that are ideal for groups, or individuals, ideal for children and adults alike. Comes packaged in a free plastic container, perfect for storage and easy transportation.

For up to 13 players

Includes: 1 15" Rainstick, 1 Bongo, 1 Congo Drum, 1 Set Wood Maracas, 1 Tambourine, 1 Musical Washboard, 2 Thimbles, 1 Wood Guiro, 1 Plastic Castanets on a handle, 1 Sleigh Bells, 1 Trapeze Bells, 1 Hand Drum, 1 4" Croaking Frog, 1 Claves

No. MTH13 Music Therapy Kit

1STNOTE® MUSICAL RHYTHM SETS

Firstnote Musical Rhythm Sets contain the finest quality musical products available to the school and home market today. Assembled with the aid of professional music educators, utmost care was given to provide children with a wide range of products in order to broaden the child's early musical experiences.

For up to 12 players

A unique collection of musical rhythm instruments. Set includes 12 easy-to-play pieces. Includes FREE durable drawstring bag to keep everything together.

Contents: 3 Kazoos, 3 Noseflutes, 1 Pair Rhythm Sticks, 2 Castanets, 1 Triangle, 1 Sleigh Bells and 1 Tambourine.

No. FN500 1st Note® Rhythm Set



TROPHY PERCUSSION

APPLECREEK™ HAND-CRAFTED TONE DRUMS

Our solid wood Tone Drums are handmade by Amish Craftsmen in Southern Ohio. Choose from our 4 or 6 tone solid Maple models or our 8 tone solid Cherry model. Each drum produces its own unique resonant tone when played with the supplied “professional quality” mallets.



- No. AC34** 4- Tone
- No. AC36** 6- Tone
- No. AC38** 8- Tone

DUPLEX® “PROFESSIONAL” WOOD BLOCKS

Professional quality blocks are made of select maple with curved striking surfaces that provide an authentic tone and good carrying power. Blocks are slotted at the top and bottom, carefully shaped and neatly beveled. Natural oil rubbed finish. Fits all standard holders.



- No. 3458** Medium, 6- 3/4”
- No. 3459** Large, 7- 1/2”

HAND-HELD WOODBLOCK



Hold in one hand and strike with the included mallet for a nice wood block effect.

- No. W402** Hand-Held Woodblock

TROPHY PERCUSSION

TONE BLOCK

Nicely finished select grade wood. 6 1/2" length. Barrel is bored and slotted to produce wood block tone. Striker included.



No. 3456 Tone Block

TWIN TONE BLOCK

Natural finished two-tone wood block. One low tone, the other a fifth higher. 7-5/8" length. Includes striker.



No. 3461 Twin Tone Block

RHYTHM GOURDS

Produces tone block sound by striking or gourd sound by scraping.



No. 3275 Rhythm Gourds

TAP-TAP BLOCKS

Large, 3" x 5" block with sturdy handle. Produces sharp "click" sound.



No. 4965 Tap-Tap Blocks

SAND BLOCKS

As above with replaceable sand paper. Produces a "swish, swish" sound.



No. 4966 Sand Blocks

RATCHET

A hardwood wheel and four tone tines are mounted between steel supports. There is a mounting bracket attached. All metal parts are heavily chrome plated.



No. 3455 Ratchet

TROPHY PERCUSSION

SPINNING DRUM



Nicely made "Spinning Drum" has real skin heads. By twisting in your hand, both of the beads strike the head causing a unique party sound. 3 1/2" head.

No. B35 Spinning Drum

HAND HELD TOM TOMS



Genuine skin heads mounted on a laminated shell. The nylon handle is mounted through the enamel coated shell. One pair of maple ball mallets provided.

No. 4980 Tom Tom

SNARE BOY AND TOM BOY



A natural calf head is mounted on a five ply, six inch maple shell. A wooden handle is securely mounted through the shell. A wooden ball mallet is provided. The SNARE BOY has two metal springs mounted beneath the head for a crisp snare sound.

No. 4981 Snare Boy

No. 4982 Tom Boy

STIRRING DRUM



"Stir" the mallet inside the "drum" to create unique tones.

No. TM18 Stirring Drum

HAND DRUM



Super thin, 10 inch hand drum with real skin heads provides an exceptionally loud and clear drum sound. A durable wood mallet is included. Assorted colors.

No. B360A Hand Drum

TROPHY PERCUSSION

SPIRIT OF "76 DRUM"



A stunning 9" x 8 1/2" drum made just as they were in the 1700's. All wood construction with real leather heads. The drum body is covered with a durable, textured material, while the rims are stained to show real wood grain. An attractive gold roping "finishes off" this beautiful drum. A pair of drum sticks are included.

No. W470 Spirit of "76 Drum"

TALKING DRUMS



Played by holding under your armpit. Squeezing the cords alters the pitch. Available in chrome and brass.

W710 10-Inch Chrome
W710B 10-Inch Brass

CONGA DRUMS



Beautiful "child-size" Conga Drums are the perfect way to introduce children to the world of percussion. Made of solid hardwoods with genuine leather heads, they include a durable and fully adjustable strap for comfort and years of enjoyment.

No. TM24 7-inch x 15-inch Conga Drum
No. TM26 7-inch x 20-inch Conga Drum

MINIATURE CONGA DRUM AND BONGO DRUMS



MINIATURE Bongo and Conga drums are the perfect size for children or just great conversation pieces. These fully tunable miniature drums look and play just like the real things. Solid hardwood and genuine leather heads they are perfect for early education classes.

No. TM22 4-1/2" Head Conga Drum

TROPHY PERCUSSION

BONGOS From Pakistan



A very well made bongo with a 7" and 6" head. Solid two tone woods and real skin heads.

No. B450 Bongo

TUNABLE BONGOS From Pakistan



Slightly larger (8"x7") than the B450 model and completely tunable for the more advanced player.

No. B460 Tunable Bongo

BONGOS



We're sure that these are the finest quality children's bongos you'll find. Very nicely made with real skin heads. 5 inch and 7 inch heads, very authentic bongo sound.

No. B370R Red Bongo

No. B370B Blue Bongo

"TRIO" DRUMS



Made of solid hardwoods and real leather heads, our new "Trio" drums are extra heavy duty, perfect for school use. Beautifully finished in colorful transparent stains. They include drumstick and cord.

No. TM10 Red 4-inch Piccolo Drum

No. TM12 Yellow 6-1/2 inch Alto Drum

No. TM14 Blue 8-1/2 inch Tenor Drum

TROPHY PERCUSSION

BODHRANS From Pakistan



A large traditional drum used in many styles of music in many parts of the world. Wood cross-bracing on back provides stability and an easy grip.

W414 14-Inch

W416 16-Inch

W418 18-Inch

FRAME DRUMS From Pakistan



Frame drums are tambourines without jingles. They produce a very resonant tone when struck with the hand or soft against the leg.

B106 6 inch Frame Drum

B108 8 inch Frame Drum

B110 10 inch Frame Drum

TAMBOURINES WITH SKIN HEADS

From Pakistan



B306 6 inch Tambourine w/ Skin Heads

B308 8 inch Tambourine w/ Skin Heads

B310 10 inch Tambourine w/ Skin Heads

B310D 10 inch With Double Row of Jingles

FISH TAMBOURINE From Pakistan



Solid hardwood tambourine with double-rows of jingles.

No. W400D Fish Tambourine

TROPHY PERCUSSION

JINGLES HEADLESS TAMBOURINES

From Pakistan



- B206** 6 inch Headless Tambourine
- B208** 8 inch Headless Tambourine
- B210** 10 inch Headless Tambourine
- B210D** 10 inch With Double Row of Jingles

*All Tambourines also available in attractive net bags for retail display. When ordering substitute W for B

TAMBOURINES



TAMBOURINE PLASTIC SHELL



8" PLASTIC SHELL TAMBOURINE is a true value. The shell is molded ABS with six sets of nickel plated jingles. The plastic head is securely fastened without the use of glue or nails, making it ideal for elementary use.

No. 4900 Tambourine

These are excellent quality tambourines. Made of wood and have real skin heads for incredible sound. Tambourines are 7-1/2" with 5 pairs of brightly plated jingles.

- B350R** Red Tambourine
- B350B** Blue Tambourine
- B350Y** Yellow Tambourine

TAMBOURINE JINGLES



Professional quality, nickel plated.
No. 3441 Jingles

TROPHY PERCUSSION

FINGER CYMBALS

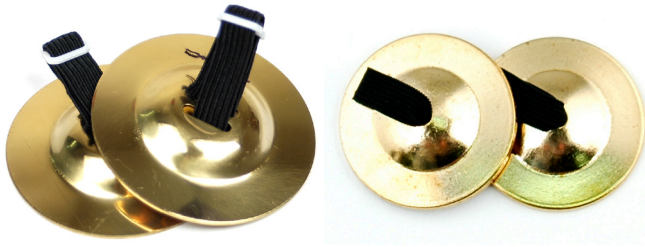

Set of 4 (2 pairs). Professional quality designed to provide a ringing, clear tone that blends and accents any compositions.

No. 3708 Steel, Brass Finish (Left)

No. 3709 Brass, Thick Cast (Right)

CYMBALS

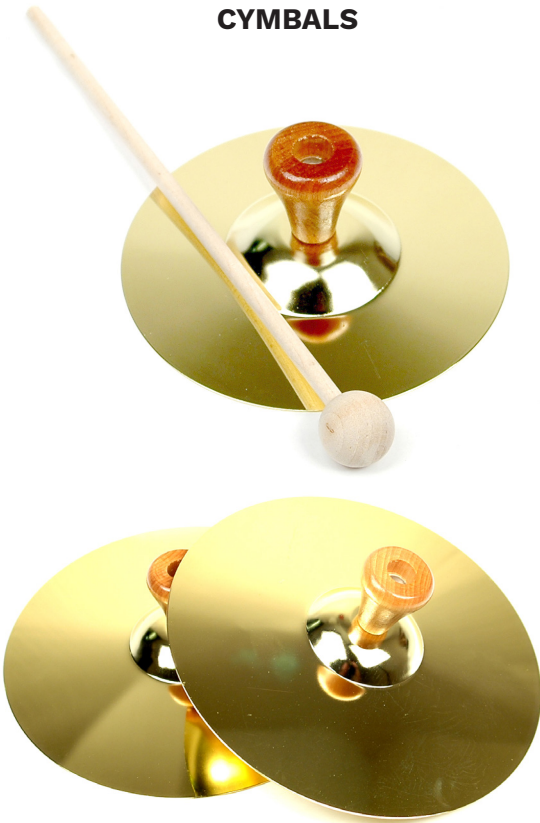

Brass alloy cymbals in both 5" and 7" sizes. Finished wooden handles are permanently fixed to cymbals. 5" cymbal is also available singly with a wooden mallet for use as suspended cymbal.

No. 3702 5" Single Cymbal w/Mallet

No. 3701 5" Cymbal, Pair

No. 3704 7" Cymbal, Pair

No. 3705 7" Single Cymbal w/Mallet

STEEL TRIANGLES Superior Quality

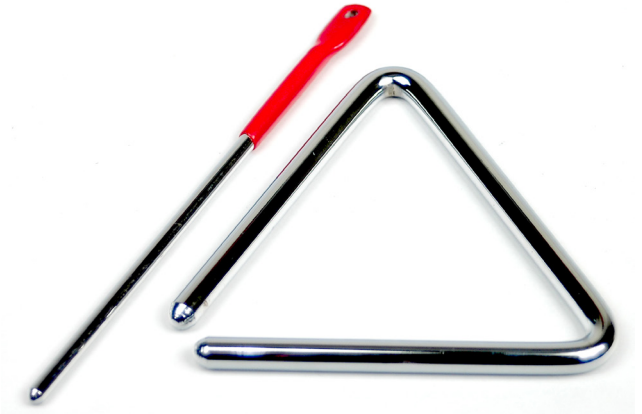

Made of top grade steel. Provides the clearest sound projection possible. Carefully plated to prevent rusting. Complete with striker, holder and clear protective bag.

No. 3504 4" Triangle

No. 3505 5" Triangle

No. 3516 6" Triangle

No. 3518 8" Triangle

No. 3515 Striker Alone

ALUMINUM TRIANGLES Superior Quality



Pure Aluminum triangles produce a very nice "ring." Made in the USA Includes holder and striker. Individually Poly-bagged.

No. AT-4 4" Triangle

No. AT-6 6" Triangle

TROPHY PERCUSSION

PLASTIC CASTANETS



Good quality. Crisp, penetrating sound.

- No. 4970** Set, 2 pair Black
- No. 4970B** Set, 2 pair Blue
- No. 4970R** Set, 2 pair Red

CASTANETS ON A HOLDER



High impact plastic. Good sound and projection. Wood handle.

- No. 4971** Set, 1 pair.

HANDLE CASTANET



Wood clappers attached to a hardwood handle with elastic for easy use.

- No. 4969** Handle Castanet

SLAP STICKS Made in U.S.A.



Best quality slap stick. Solid maple is hand oil rubbed for an attractive finish. Strong hinge and spring will provide years of use.

- No. 3464** 15" Slap Stick
- No. 3465** 18" Slap Stick

RHYTHM STICKS

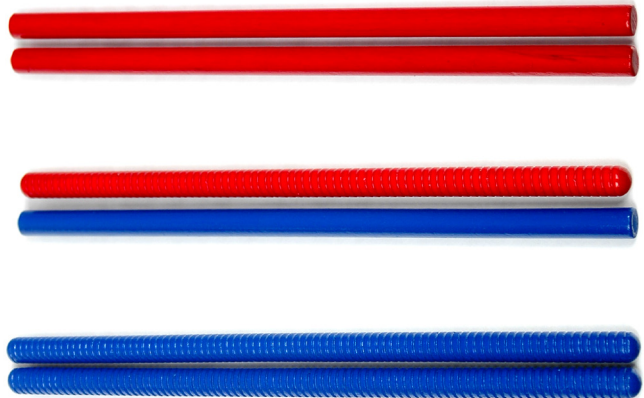

Made of select grade hardwood for durability and sharp tone.

- No. 3277** One Plain, One Fluted (Bulk)
- No. 3277B** One Plain, One Fluted (Bagged)
- No. 3276** Two Plain (Bulk)
- No. 3276B** Two Plain (Bagged)
- No. 3278** Two Fluted (Bulk)
- No. 3278B** Two Fluted (Bagged)

TROPHY PERCUSSION

CLAVES (clã vás)



Made from exotic hardwood. Are professional quality

No. B4961 Claves

CLAVES



Hardwood Claves are manufactured in the U.S.A. Striking them together produces a sharp percussion accent.

No. 4963 Claves

MARACAS



Authentic wood maracas are completely hand painted and finished to a beautiful high gloss.

No. B4956 Maracas Painted Large
No. B4958 Maracas Painted Medium
No. B4957 Maracas Natural Large
No. B4959 Maracas Natural Medium

MARACAS From Pakistan



Made from a very exotic dark wood from Pakistan these maracas are slightly heavier with larger beads than their Mexican counterparts and produce a louder, more cutting sound.

No. B4962 Maracas

TROPHY PERCUSSION

JAW HARPS made in Austria



Simply "The Finest Available"

Available in soprano, alto, and tenor sizes. Individually blister carded on a beautiful, four color display for impulse sales.

No. 3492 Soprano

No. 3493 Alto

No. 3494 Tenor

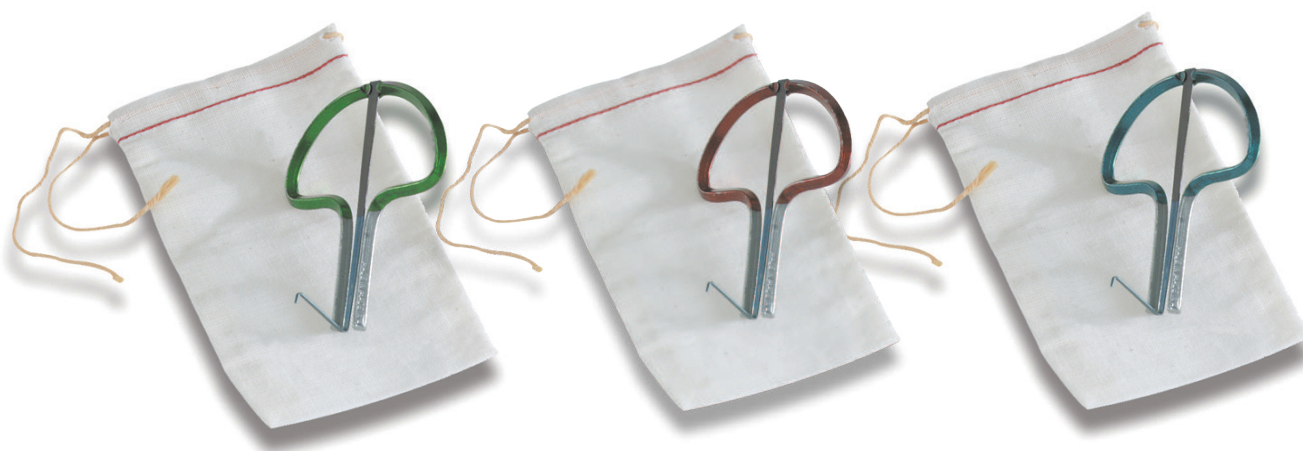

Handmade and individually tuned, these beautiful Jaw Harps from Austria are the best sounding and easiest to play. Each Jaw Harp comes in a handy draw string bag.

No. W32 Soprano

No. W33 Alto

No. W34 Tenor

TROPHY PERCUSSION

GT MINI PLASTIC MARACAS



These high quality miniature versions of professional maracas are used in just about every style of music today. Carefully designed to produce an authentic tone, they are made of specially formulated plastic that will last a lifetime. Small enough to use anywhere, but loud enough for stage use. **Simply the BEST!** Available in attractive clear cylinders or Clam-Shells.

In Clear Cylinder

- No. **GT14** Blue
- No. **GT16** Black
- No. **GT18** Green
- No. **GT20** Purple
- No. **GT22** Orange
- No. **GT24** Red
- No. **GT26** Yellow

In Clam-Shells

- No. **BLP14** Blue
- No. **BLP16** Black
- No. **BLP18** Green
- No. **BLP20** Purple
- No. **BLP22** Orange
- No. **BLP24** Red
- No. **BLP26** Yellow

TARACAS

Brightly colored Taracas, come in 4 different sizes, offering slightly different tones, ranging from high to low.

Packaged in a net bag and sold as a set of 4, makes them perfect for group play! Try them out today!

- No. **FN252** Set of 4 Taracas



TROPHY
PERCUSSION

SHAKIN' EGGS



These “mini-maracas” are made of durable ABS plastic and are ideal for teaching different rhythm and beats. Used in all styles of music they produce that commonly heard swish-swish sound. They are suitable for children ages 3 & up. 1.535”W x 2.17”H

- No. BESP** Pink
- No. BESR** Red
- No. BESO** Orange
- No. BESY** Yellow
- No. BEG** Green
- No. BESBL** Blue
- No. BESP** Purple
- No. BESBK** Black
- No. BESW** White

JUMBO SHAKIN' EGGS

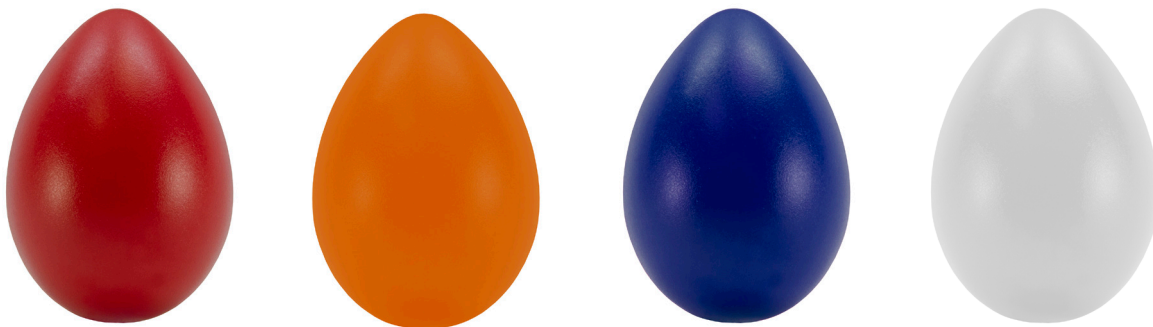

Our Jumbo Shakin' Eggs are slightly larger than our standard size Shakin' Eggs for a 0+ age grade. Made of durable ABS plastic and are ideal for teaching different rhythm and beats. Used in all styles of music they produce that commonly heard swish-swish sound. They are suitable for children ages 0 & up. 1.773”W x 2.452”H

- No. JBESR** Red
- No. JBESO** Orange
- No. JBESBL** Blue
- No. JBESW** White

TROPHY PERCUSSION

TRAPEEZE JINGLES



Super quality, all hardwood construction, simply hold the handle in one hand and tap the “ball end” in the palm of your other hand for a nice tambourine sound.
No. W405 Trapeeze Jingles

TRAPEEZE BELLS



Super quality, all hardwood construction, simply hold the handle in one hand and tap the “ball end” in the palm of your other hand for a nice jingle bell effect.
No. W406 Trapeeze Bells

SLEIGH BELLS Made in U.S.A.



Single Row Model with 13 bells. Large nickel plated bells mounted securely on a beautifully finished solid handle. Produces loud, vibrant sound. The best made!
No. 3567 Single Row Model

SLEIGH BELLS Made in U.S.A.



Double Row Model with 25 bells. Large nickel plated bells mounted securely on a beautifully finished solid handle. Produces loud, vibrant sound. The best made!
No. 3568 Double Row Model

SLEIGH BELLS



5- 1/2” Sleigh Bells are entirely made in the U.S.A. 6-1” nickel plated bells produce authentic “Sleigh” sound at a very moderate price.
No. 3569 Sleigh Bells

WRIST / ANKEL BELLS



Four 1 -inch nickel plated bells on a 3/4” webbed strap. Very good quality.
No. 3571 Wrist/Ankle Bells with Velcro®
No. 3073 Same as above, but without Velcro® (Non-adjustable)

TROPHY PERCUSSION

CLUSTER BELLS



Three nickel, silver bells riveted to a plastic strap. Plastic strap is riveted to form handle.

No. 3566 Cluster Bells

RHYTHM BELLS



Bright, nickel plated brass with non-toxic enameled handle. Nice tone.

No. 3072 Rhythm Bells

JINGLE CLOGS



Wood handle is nicely shaped for a comfortable grip. Two high quality jingles for good tone. Played by tapping or shaking like a tambourine.

No. 3201 Jingle Clogs

"DELUXE" HANDBELL SET



Set of eight Diatonic Handbells with a range of C-C. The 2" high x 2-7/8" diameter metal bell is powder coated in seven attractive colors. The tapered, plastic handle has the note designated on the end and is 3-1/2" long with a 3/4" diameter, making it easy to hold. The plastic spring-loaded clapper produces a clear, crisp sound. Each set is boxed in a colorful display carton.

No. 4770 Handbell Set

SWISS MELODY BELLS



The perfect way to introduce children to music at home or in the classroom. Swiss Melodee Bells are simple to play. Each bell is individually colored and note marked so that virtually anyone can learn to play. Song book contains songs that are familiar to everyone. Accurately tuned F to F.

No. 4766 Swiss Melodee Bells

TROPHY PERCUSSION

XYLOPHONES

25- NOTE CHROMATIC MODEL (A to A)

Two chromatic octaves with crisp resonance and projection. Each chrome steel bar is electronically tuned for excellent pitch. The case is high impact plastic for added durability. Includes plastic mallets.



No. T1700 25- Note Set

27- NOTE CHROMATIC MODEL (G to A)

Twenty seven bar chromatic bell set with a range from G below middle C to A. Metal bars are electronically tuned to insure proper pitch. The 1" bars are permanently mounted in the plastic carrying case. The natural notes are white and the bars for the half tones are black to resemble a piano keyboard. Two sets of mallets are provided.



No. T1727 27- Note Xylophone

8- NOTE BELLS SET

8- Note resonator bells in a unique attache case. Bells can be removed from case and held in hand by multiple players. Perfect for school use. Includes mallets.



No. T1750 8- Note Set

TROPHY PERCUSSION

DIATONIC BELL SETS

All DUPLEX® Diatonic and Chromatic Bell Sets are made with a select hardwood frame for excellent projection, resonance and durability. All bars are pure steel and electronically tuned to A-440 for accurate intonation. Bars are 1-1/4" wide, spaced for easy play and attached securely to the frame.

ALL "DUPLEX" Bell Sets are individually boxed and include mallets.

CHILDREN'S 8- NOTE BELL SET (with colored bars) (C to C)



Specifically designed for primary grades using colorful bars to help children with note/color recognition.

No. TR9005 8- Note Set

8- NOTE BELL SET (C to C)

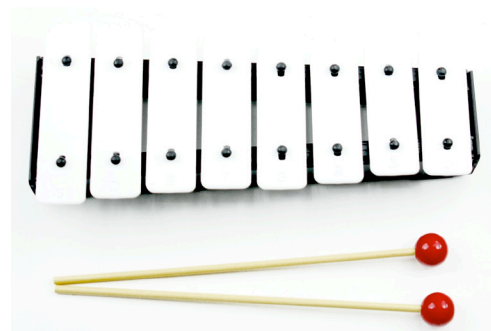

No. TR9021 8- Note Set

8- NOTE STEP BELLS (C to C)

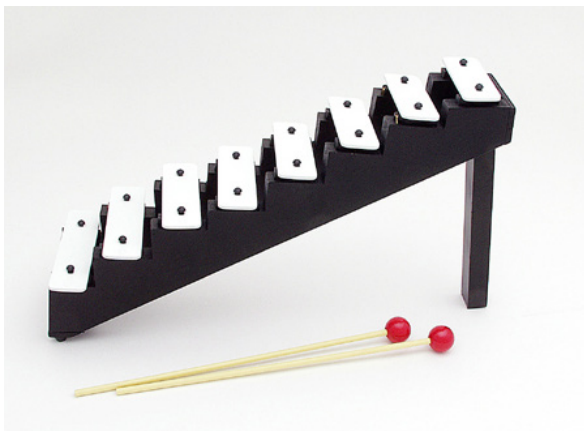

Ideal for the primary grades. Ascending scale and steps helps children visualize the concept of pitch.

No. TR9011 8- Note Set

12- NOTE BELL SET (C to G)

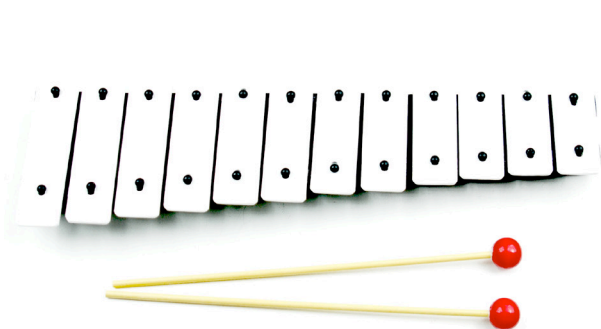

No. TR9008 12- Note Set

TROPHY PERCUSSION

CHROMATIC BELL SETS and BELL SETS

**20- NOTE BELL SET
(C to G)**

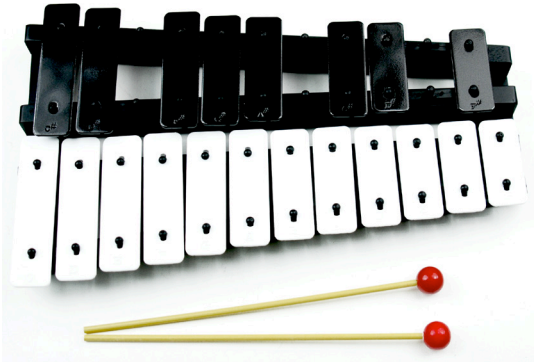

No. TR9004 20- Note Set

**17- NOTE BELL SET
(C to E)**

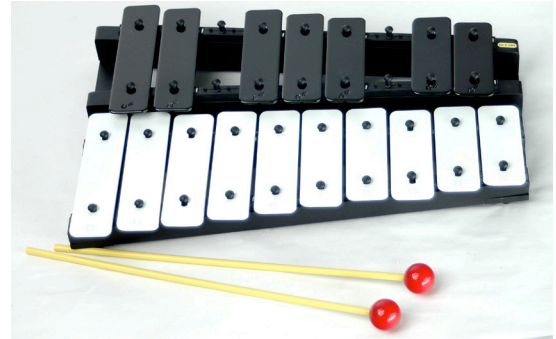

No. TR9017 17- Note Set

25- NOTE BELL SETS



(A to A)
No. TR9001 25- Note Set



(G to G)
No. TR9012 25-Note Set

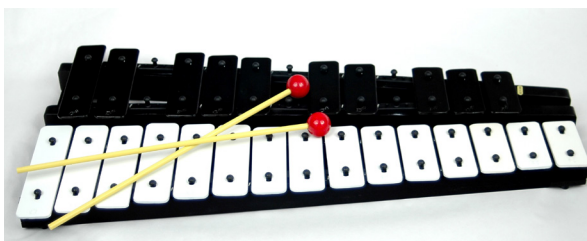

(C to C)
No. TR9007 25-Note Set

TROPHY PERCUSSION

RESONATOR BELLS

Bars are 1 1/4" wide x .125" thick made from bell quality steel. Each bell is individually tuned to insure uniformity from set to set as well as with in each set. The natural notes are in the white baked finish while the half tones are black. The tone chambers are made of High Impact ABS plastic to enhance the resonance. Luggage style case with removable lid available. The removable lid facilitates playing bells with ease. Each set complete with one mallet per bell.

20- NOTE RESONATOR BELLS WITH CASE



No. TR2121 Beginning with middle "C" with hard shell case

25- NOTE RESONATOR BELLS WITH CASE



No. TR2122 Beginning with "G" below middle "C"

STEP LADDER FOR BELLS



Visualize the concept of pitch by arranging bells on the step ladder. Lower notes on the bottom higher at the top. The relationship of the pitch becomes clear to the student.

No. TR991 Bell Ladder

TROPHY

PERCUSSION ACCESSORIES

DRUM CLINIC

A practical selection of the most asked for replacement parts. Designed to get the parts out of drawers and bins and up onto the counter where customers can see them!

Drum Clinic parts are all top quality-to satisfy every drummer. They are attractively and durably skin packaged for long shelf life and to encourage impulse sales.



- No. DC10** Snare Drum Cord (2/CD)
- No. DC14** Cymbal Washers (2/CD)
- No. DC18** Cymbal Sleeves (4/CD)
- No. DC26** Rubber Tips (3/CD)
- No. DC30** Leather Foot Pedal Strap (1/CD)
- No. DC34** Drum Key (1/CD)
- No. DC40** 1-1/2" Tension Rods (4/CD)
- No. DC42** 2" Tension Rods (4/CD)
- No. DC44** 2-1/2" Tension Rods (4/CD)
- No. DC46** 3" Tension Rods (4/CD)
- No. DC48** 3-1/2" Tension Rods (4/CD)

TROPHY

PERCUSSION ACCESSORIES

DUPLEX® HEAD SAVER PADS



Protects and extends the life of bass drum heads. Pressure sensitive. 3 1/2" diameter.
No. 3269 Bag of 12 Pads U.S.A.

BASS DRUM SPUR HOLDER



Non-skid waffle pattern foam holder.
Metal cup.
No. 4080 Spur Holder

DUPLEX® DRUM KEY



Top Steel, specially designed to fit triple flange hoops as well as "L" hoops. Chrome plated

No. 3732 Drum Key

CYMBAL WASHERS



Top quality felt, carefully made to stand up under hard use. Every drummer should have several "extras."

No. 3198 Cymbal Washers, DOZEN

RUBBER TIPS



Specially molded tips, for durability and long, dependable service. Used extensively for spurs, stands, Tom- Tom legs, ect.

No. 3281 Rubber Tips, DOZEN

CYMBAL SLEEVES



Top quality, clear plastic sleeves for cymbal holders and stands offer excellent protection.

No. 3288 Cymbal Sleeves, DOZEN

CYMBAL STAND WING NUT



Standard threading fits most stands.

No. 3289 Wing Nut

TROPHY

PERCUSSION ACCESSORIES

DUPLEX® MALLETS, BRUSHES

“NYLO-TEX” BELL LYRA MALLETS

One piece solid nylon mallets. No ball or handle to come loose. Produces brilliant, clear tone and will last for years.



No. 1740R White



No. 1740RB Black

“SAFETY MALLETS”

1 pc. molded mallet is made of durable ABS plastic.

No. TR9300 Safety Mallet



“ECONOMY” XYLOPHONE MALLETS

For Bells, Hand Drums, Tone Blocks and Glocks

No. TR9306 Wood Ball Pair



No. TR9312 Rubber Ball Pair



DRUM BRUSHES

Drummers will be delighted with these responsive brushes and their outstanding durability.

No. 4826 Rubber Coated Handles, “Snap out” Style. Pair



No. 4827 Rubber Coated Handles, Loop Ends. Pair



TROPHY

PERCUSSION ACCESSORIES

DUPLEX® PEDAL BEATERS

Professional Quality

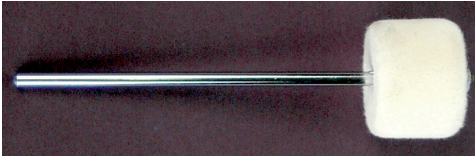

Felt Ball Bass Drum Pedal Beater. Chrome plated steel post.

No. 3261 Felt Ball



Wood Ball Bass Drum Pedal Beater. Chrome plated steel post.

No. 3262 Wood Ball

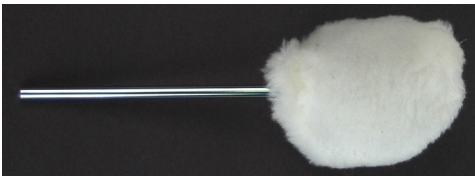

Lamb's Wool Ball Bass Drum Pedal Beater. Chrome plated steel post.

No. 3264 Lamb's wool ball



Cork Ball Bass Drum Pedal Beater. Chrome plated steel post.

No. 3265 Cork Ball



REPLACEMENT STRAP

Genuine leather strap fits all drum pedals.

No. 3090 Replacement Strap

DUPLEX® PRACTICE PADS

“STUDIO” PRACTICE PAD



A durable and practical drum pad. Size: 6 5/8" x 5". Rubber pad gives “bounce” and provides the kind of live action drummers want. Recommended by percussion teachers.

No. 3561 Practice Pad U.S.A.

DRUM PRACTICE PAD

Gladstone Style



Made of pure rubber. The DUPLEX® pad offers two playing surfaces while a vacuum cavity holds the pad firmly in place on the drum head. Gives the drummer a natural feel, with audible response.

No. 3565 Practice Pad

TROPHY

PERCUSSION ACCESSORIES

DUPLEX® SNAPPY SNARES™

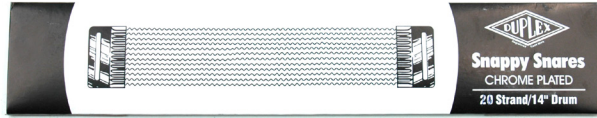

Made of special quality CHROME PLATED coiled steel wire. Trenched butt plates provide for better response. Individually packaged.

12 Strand

No. 3351 For 13" drum

No. 3352 For 14" drum

16 Strand

No. 3356 For 14" drum

20 Strand

No. 3361 For 14" drum

No. 3362 For 15" drum

DUPLEX® 42 STRAND ROCK 'N' ROLL SUPER SNARE

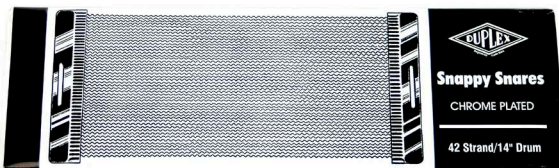

Extra wide, CHROME PLATED, 42 strands, activates a greater area of the head and provides extra power which is highly desired by today's drummers. Individually carded with nylon cord and wrapped in polyethylene.

No. 3395 For 14" Drum

DUPLEX® SNAPPY SNARE™ STRINGS



Made of Specially Braided White Cotton. Snappy Snare strings, packed two 10" lengths in a poly bag with header.

No. 3370 Bag of 2

DUPLEX® SNARE STRAINER

Precision Engineered



Gives the professional percussionist smooth, trouble free action without slip or slide. Has non-slip, plastic topped throw-off arm. All parts are heavily chrome plated. With back plate.

No. 3386 Snare Strainer

KEY TENSION RODS



Key Tension Rods, square head, triple plated. Specify size. (Length from under collar to threaded end.)

No. 3630 1-1/2"

No. 3631 2"

No. 3632 2-1/2"

No. 3633 3"

No. 3634 3- 1/2"

No. 3635 4"

No. 3636 4- 1/2"

No. 3637 5"

TROPHY

PERCUSSION ACCESSORIES

HI-HAT CLUTCH



Well made, practical and economical. Designed for utility and durability. An outstanding replacement model.

No. 3825 Hi-Hat Clutch

HI-HAT CLUTCH



New, bottom threaded shank prevents clutch from working loose. Provides wing nut and knurled nut adjustment. Felt washers hold cymbals firmly while allowing free cymbal response. Fits all rods - hex and round.

No. 3826 Hi- Hat Clutch

“STA-FAST” WOOD BLOCK HOLDER



Heavy Duty, Chrome Plated. Attaches to hoop. Holds any sized wood block.

No. 3827 Wood Block Holder

COMBINATION WOOD BLOCK AND COWBELL HOLDER



Chrome Plated Wood block and cowbell holder combination. Holds any sized wood block and cowbell. Attaches to bass drum hoops.

No. 3828 Combination Holder

COWBELL HOLDER



Chrome Plated cowbell holder. Holds any sized cowbell. Attaches to bass drum hoops.

No. 3095 With 6” post and “U” clamp.

BASS DRUM ANCHOR

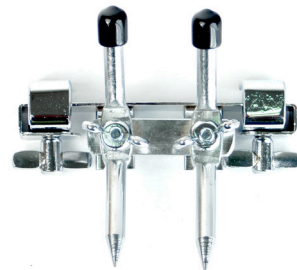

An Indispensable Accessory. The anchor that is considered to be “standard” with most top flight professional drummers. Positively stops bass drums from creeping. Reversible rubber or pointed tips. Chrome plated.

No. 3829 Bass Drum Anchor

TROPHY

PERCUSSION ACCESSORIES

FLOOR BONGO STAND

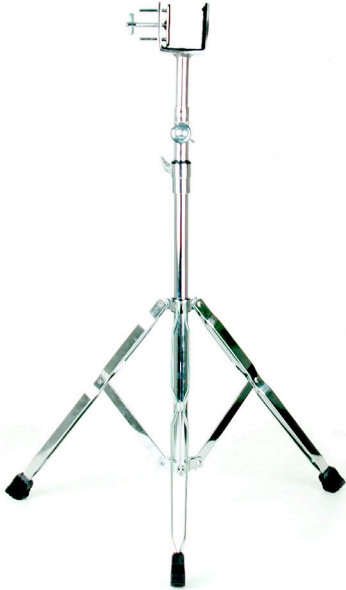

“Universal Model” fits virtually all models. Special tension bracket and horizontal support bar for maximum stability. Has large wing nuts for fast and easy adjustments.

No. 3815 Bongo Stand

“PRO” BASS DRUM RACK



1” diameter steel tubing, heavily chrome plated with rubber crutch tips. Top has 4 extra thick felt pads to cushion drum properly. Accommodates large bass drums. Notched side arms for easy adjustments. Won’t rock or sway. Two web straps and metal buckles. Folding frame is easily portable. Folds to 24” wide x 31”high, 8 lbs. Ideal for any symphony.

No. 3002 Bass Drum Rack Made in U.S.A.

CONCERT CYMBAL STAND FOR CONCERT BAND AND ORCHESTRA



Sturdy, fully adjustable cymbal stand that will hold all sizes of cymbals. Over sized wing nuts make adjustments fast and easy. Holder arms are covered with neoprene to protect cymbals. Heavily chrome plated. Rubber tipped feet.

No. 4360 Cymbal Stand

TROPHY

PERCUSSION ACCESSORIES

MARCHING BANS ACCESSORIES

DELUXE® DRUM SLINGS

Strong- Durable- Practical



Made for strength and durability. Practical, and neat. Adds zest to any uniform! Tough Polyester will not stretch, slip or shrink. Fully adjustable with extra heavy swivel hook. 2" wide webbing. Has tremendous appeal to Legion Drum and Bugle Corps, High School Bands, College Bands, Community Bands, ect.

No. 3312 White Polyester

LAMB'S WOOL PAD AND LEATHER STRAP SETS



Set consists of two No. 3193 pads and two No. 3192 straps.

No. 3190 Pad Set, PAIR

LEATHER PADS



Top grain, double leather cymbal pad with heavy felt interlining. Permits full cymbal vibration and protects knuckles. Individually wrapped.

No. 3191 Cymbal Pad, PAIR

LEATHER STRAPS



Cymbal strap to match No. 3191. Individually wrapped.

No. 3192 Straps, PAIR

TROPHY

PERCUSSION ACCESSORIES

MARCHING BANS ACCESSORIES

LAMB'S WOOL PADS



Professional quality pad, heavy lamb's wool covered top grain leather with felt insert. Individually wrapped.

No. 3193 Cymbal Pad, PAIR

SURE-GRIP HOLDERS



Cymbal holders. Hardwood handle, neatly shaped. Sealed and lacquered. Strong, adjustable leather strap.

No. 3176 Sure-Grip Holders, PAIR

LAMB'S WOOL STRAPS



Cymbal strap, lamb's wool on rawhide. Individually wrapped.

No. 3194 Strap, PAIR

LEATHER PAD AND STRAP SETS

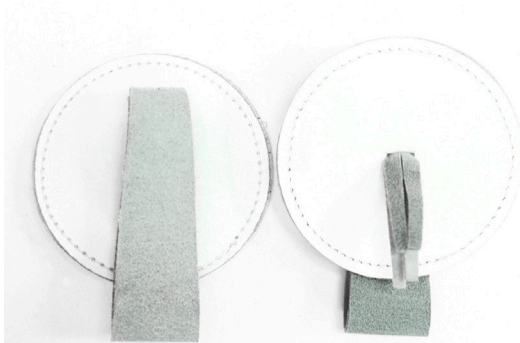

Set consists of two No. 3191 pads and two No. 3192 straps.

No. 3195 Pad Set, PAIR

TROPHY

BRASS and WOODWIND ACCESSORIES

STERISOL®

STERISOL® “The Red Stuff”

For school and studio - Cleans - Deodorizes - Freshens

For all wind instruments

Positive cleaning action in one minute. Safe to use: Non-irritating to mouth and throat, Nonpoisonous, Harmless to metals, lacquer, wood, hard rubber and plastic.

Read to use and Concentrate

To clean: Immerse mouthpieces, reeds and pre-band instruments for one minute. Rinse with clean water.

2oz. CONCENTRATE



No. 1874

2-oz. Bottle, concentrate. (Makes one quart)

8oz. CONCENTRATE

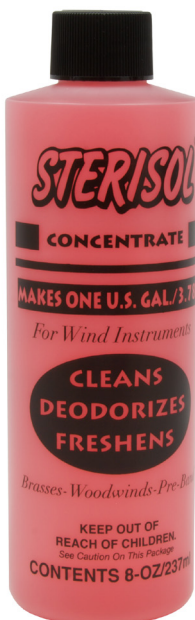

No. 1875

8-oz. Bottle, concentrate. (Makes one gallon)



No. 1885

8-oz. Bottle, Ready to use spray bottle.

***Bands* StandTM**
Quality Band Products

TROPHY

BRASS and WOODWIND ACCESSORIES

FLIP FOLDERS

The flip folder has a molded back with reinforced sides. There is a molded channel in each side for a sure fit grip, regardless of lyre style. Each flip folder is provided with five crystal-clear music pockets mounted on two steel rings. Replacement rings and extra windows are available



FOR MARCHING BAND

- No. **TR9400** Flip Folder Black
- No. **TR9420** Flip Folder Blue
- No. **TR9422** Flip Folder Green
- No. **TR9424** Flip Folder Orange
- No. **TR9426** Flip Folder Purple
- No. **TR9428** Flip folder Red
- No. **TR9430** Flip Folder White
- No. **TR9401** Windows
- No. **TR9402** Rings
- No. **TR9412** Windows 12 pack



TROPHY

BRASS and WOODWIND ACCESSORIES



TROPHY'S BAND STAND™ INSTRUMENT LYRES

Here's a precision-made line of instrument lyres that provide quality and durability at reasonable costs. Designed for the rigors of marching band, "BAND STAND™" lyres meet every requirement.

G = Gold N = Nickel

- No. **TR9500G** Straight Trumpet Lyre, 4" stem
- No. **TR9500N** Straight Trumpet Lyre, 4" stem
- No. **TR9500LG** Straight Sousaphone Lyre, 8" stem
- No. **TR9500LN** Straight Sousaphone Lyre, 8" stem
- No. **TR9500MG** Straight Baritone Lyre, 6" stem
- No. **TR9500MN** Straight Baritone Lyre, 6" stem
- No. **TR9501G** Trumpet Lyre, bent stem
- No. **TR9501N** Trumpet Lyre, bent stem
- No. **TR9502N** Universal Trumpet Lyre, clamp on
- No. **TR9506N** Clarinet Lyre with ring
- No. **TR9506MN** Clarinet Lyre only
- No. **TR9506NR** Clarinet Lyre ring only
- No. **TR9510N** Wrist Lyre, 2-piece for flute/piccolo
- No. **TR9513N** Flute Lyre, 2-piece clamp on
- No. **TR9511G** Trombone Lyre, 1-piece, 9/16"
- No. **TR9511N** Trombone Lyre, 1-piece, 9/16"
- No. **TR9514G** Trombone Lyre, 2-piece, 9/16"
- No. **TR9514N** Trombone Lyre, 2-piece, 9/16"
- No. **TR9517G** Saxophone Lyre
- No. **TR9517N** Saxophone Lyre

TROPHY

BRASS and WOODWIND ACCESSORIES

MOUTHPIECES

Exceptional quality mouthpieces are entirely made in the U.S.A. Attractive, high gloss ABS Plastic provides excellent tone and durability. **Available in the most popular facing to fit most needs.** Perfect for students and OEM replacements. Attractively skin packaged on a four color display card for durable and sanitary display. **Available in bulk!**

BC
Clarinet

BA
Alto Sax

BT
Tenor Sax



Mouthpieces

No. BC	Clarinet (B ^b)	Bulk Uncarded
No. BA	Alto Sax (E ^b)	Bulk Uncarded
No. BT	Tenor Sax (B ^b)	Bulk Uncarded
No. BSC	Clarinet (B ^b)	Display Card
No. BSA	Alto Sax (E ^b)	Display Card
No. BST	Tenor Sax (B ^b)	Display Card

Mouthpiece Sets with cap and ligatures

No. BS1N	Clarinet with nickel cap
No. BS1NP	Clarinet with plastic cap
No. BS2N	Alto sax with nickel cap
No. BS2NP	Alto sax with plastic cap
No. BS3N	Tenor sax with nickel cap
No. BS3NP	Tenor sax with plastic cap



TROPHY

BRASS and WOODWIND ACCESSORIES

METAL MOUTHPIECE CAPS

N = Nickel G = Gold



Bandstand™ Metal mouthpiece cap is designed to help protect the mouthpiece on your Bb Alto and Tenor Saxophone.

- No. TR9326N** Bb Alto Sax cap Nickel
- No. TR9328N** Bb Tenor Sax cap Nickel
- No. TR9326G** Bb Alto Sax cap Gold
- No. TR9328G** Bb Tenor Sax cap Gold

PLASTIC MOUTHPIECE CAPS



Bandstand™ Plastic mouthpiece cap is designed to help protect the mouthpiece on your clarinet.

- No. 3271** Clarinet
- No. 3272** Alto Sax
- No. 3273** Tenor Sax

SAX END PLUGS



Bandstand™ durable Plastic, Sturdy, Long-lasting. Provides necessary protection against bumping or denting.

- No. 3286** Alto Sax
- No. 3287** Tenor Sax

LIGATURES

N = Nickel G = Gold

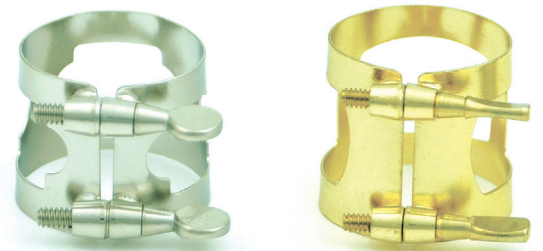

Bandstand™ ligatures feature a two-screw, non-inverted design. Designed to fit most standard Saxophone mouthpieces.

- No. TR9331G** Soprano Sax ligature
- No. TR9331N** Soprano Sax ligature
- No. TR9332N** Bb Soprano Clarinet ligature
- No. TR9334G** Bb Alto Sax ligature
- No. TR9334N** Bb Alto Sax ligature
- No. TR9336G** Bb Tenor Sax ligature
- No. TR9336N** Bb Tenor Sax ligature
- No. TR9337G** Baritone Sax ligature
- No. TR9337N** Baritone Sax ligature
- No. TR9596N** Ligature Screws
- No. TR9596G** Ligature Screws

TROPHY

BRASS and WOODWIND ACCESSORIES

MAINTENANCE KITS

Here's the complete kit to maintain your musical instrument so it will keep looking and working just like new!

No. BSK2 FLUTE

Contains:

- Cleaning Cloth
- Key Oil
- Polishing Cloth



No. BSK4 CLARINET (Composition)

Contains:

- Cork Grease
- Mouthpiece Brush
- Swab
- Polishing Cloth



No. BSK6 TROMBONE

Contains:

- Super Oil
- Mouthpiece Brush
- Flexible Cleaner
- Polishing Cloth



No. BSK8 TRUMPET/CORNET

Contains:

- Super Oil
- Mouthpiece Brush
- Flexible Cleaner
- Polishing Cloth
- Slide Grease
- Valve Casing Brush



No. BSK10 CLARINET (WOOD)

Contains:

- Bore Oil
- Cork Grease
- Mouthpiece Brush
- Swab
- Polishing Cloth

No. BSK12 SAXOPHONE

Contains:

- Cork Grease
- Swab
- Key Oil
- Polishing Cloth
- Mouthpiece Brush
- Neck Cleaner



TROPHY

BRASS and WOODWIND ACCESSORIES

BRUSHES



Nylon bristles, coiled wire rods. Zip-lock poly display bags.

No. 3232 Valve Casing Brush

No. 3241 Reed Mouthpiece Brush

No. 3242 Brass Mouthpiece Brush

BORE CLEANERS



A necessary accessory for every musician. Keeps instruments clean and sanitary. Made of flexible, sturdy, nickel-plated coil wire.

No. 3230 Trumpet/Cornet Bore Cleaner
Stiff, durable horsehair bristle brushes at both ends.

No. 3231 Trombone/Baritone Bore Cleaner
Stiff, durable horsehair bristle brushes at both ends.

No. 3236 Sax Neck Cleaner
Stiff bristle brush at one end, soft polishing swab at the other end.

SWABS



FOR SAXOPHONE

An outstanding cleaner. Includes a durable bristle brush, fine quality felt cloth and a carefully made metal weight. Packaged in a “see-thru” poly hanger bag.

No. TR300



FOR CLARINET

Includes the finest quality felt cloth, strong cord and carefully made weight. Packaged in a “see-thru” poly hanger bag.

No. TR200

SWABS FOR WOODWINDS



Made of soft wool yarn with sturdy wire and wire loop end.

No. 3282 For Piccolo

No. 3283 For Flute

No. 3284 For Clarinet

No. 8490 For Soprano Recorder

No. 8491 For Alto Recorder

No. 8492 For Tenor Recorder

TROPHY

BRASS and WOODWIND ACCESSORIES

CLEANING CLOTH

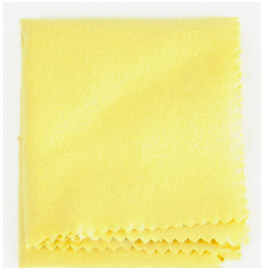

CLEANING CLOTH

Soft lint free cotton Flannel.

No. TR110 Cleaning Cloth

FLUTE CLEANING ROD



Sturdy aluminum flute cleaning rod. Has slotted head and machine groove to reset cork at proper depth.

No. 2720

LUBRICANTS

BANDSTAND™ GREASE



“Tube” Style Applicator.

Bulk packaged for Greater Savings.

No. TR150 Cork Grease

No. TR154 Slide Grease

BANDSTAND™ OIL



One of the fastest, slickest, most effective oils ever developed. For valve and slide instruments. 1-1/4oz. In clear, plastic bottle. Bulk packed.

No. TR350 Super Oil

No. TR352 Bore Oil

No. TR354 Key Oil

TROPHY

BRASS and WOODWIND ACCESSORIES

“THUM-EEZ” THUMB PROTECTORS



“THUM-EEZ” Packed separately in poly bags. Fits over thumb rest. Helps maintain proper finger position.

No. TR2203 For Clarinet

No. TR2203 For Clarinet

FLUTE HEAD CORKS



1” Long, 11/16” Diameter with
1/8” Hole

No. 2738 PER DOZEN

NATURAL CORK SHEETS



Selected quality, imported, natural cork sheets. An indispensable item for the musical instrument repairman. Supplied in the most popular thicknesses.

No. 2196 12” long x 4” wide x 1/32” thick

No. 2197 12” long x 4” wide x 1/16” thick

No. 2198 12” long x 4” wide x 3/32” thick

BANDSTAND™ LONG MUSIC CLIP



Sturdy wood base with flexible, clear plastic top. 10” long. Nickel plated spring provides strong holding action under any circumstance.

No. 4075

TROPHY

BRASS and WOODWIND ACCESSORIES

“TIGER” MOUTHPIECE PULLER

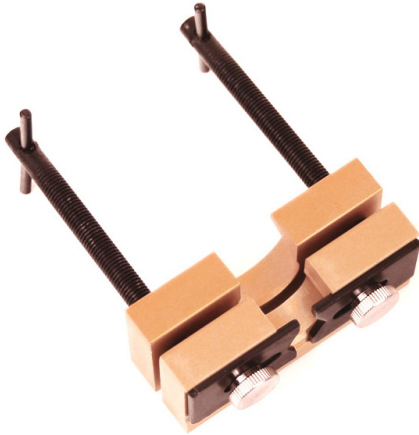

Sturdy, portable with uniquely designed, adjustable jaws. Made of anodized blocks of aluminum, precision machined to fit any brass instrument and easily remove any stuck mouthpiece without leaving marks. The locking screws quickly open jaws to fit specific mouthpiece, then just as quickly locks it in place. Threaded rods turn evenly until mouthpiece is free.

No. T105

COLLARS FOR REPLACEMENT

No. 102 Complete Set (20 Halves)

VALVE PROTECTORS TRUMPET/CORNET



Soft leather, velveteen lined with Velcro® closure

No. TR01800

STAND BAGS



Deluxe nylon snap bag for folding music stands:

No. BS10B fits 600 Series Stands (23" x 5")

No. BS12B fits 400 Series Stands (19" x 5")

WOODWIND STRAPS

Excellent quality straps are made in the U.S.A. In poly bag with colorful header.



No. AT1B Standard, Black



No. AT2BV Deluxe, Black

*ALL STRAPS FIT ALTO AND TENOR SAX

TROPHY

BRASS and WOODWIND ACCESSORIES

MUSIC STAND LAMPS

“Bandstand®” orchestral lamps are the finest quality available. Extremely durable and built to withstand years of travel and installations. Individually packaged in durable corrugated display boxes.

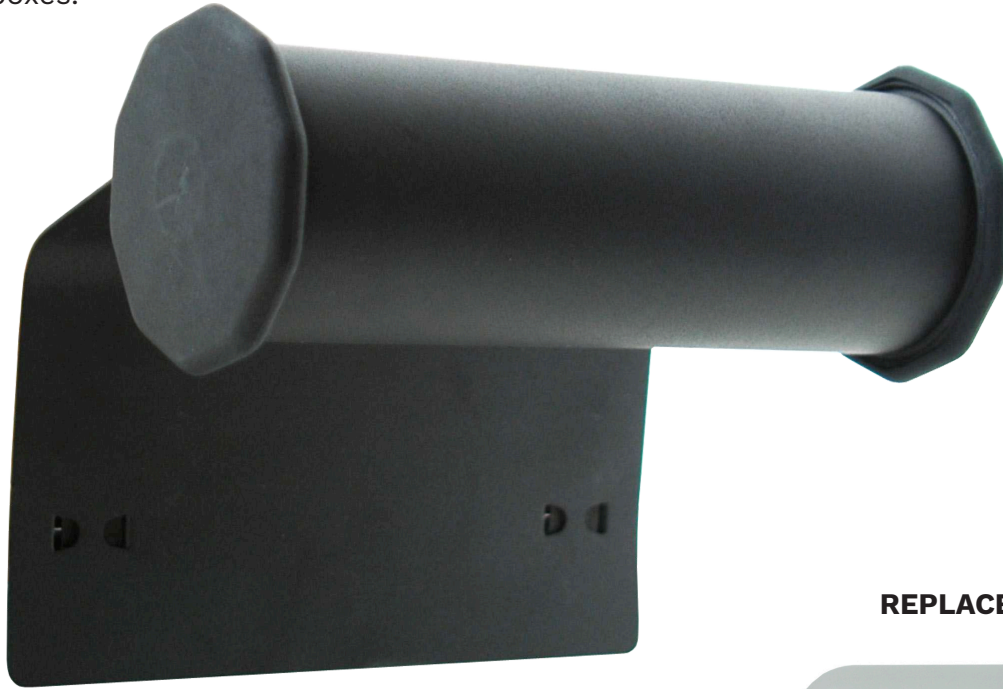

Strong tension springs for all solid back stands. (Bulb included).

No. BLS-2 Music Stand Lamp

REPLACEMENT BULB

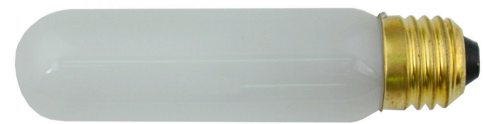

No. T10 40 Watt Light Bulb

TUNING HAMMERS

PIANO



Practical, rigidly made and moderately priced tuning hammer. Hardened, plated steel for durability. Handle is specially contoured for maximum hand comfort and vibration insulation. Individually boxed.

No. 8024 Hammer with “STAR” head

No. 8025 Hammer with “SQUARE” head

No. 8026 Head only “STAR”

No. 8028 Head only “SQUARE”

No. 8027 Handle assembly only

AUTOHARP



Hardened steel shaft is chrome plated. Comfortable plastic handle. Individually poly bagged.

No. 8020 Tuning Hammer

TROPHY

JUST IN CASE HARDWARE

REPLACEMENT HARDWARE FOR CASES

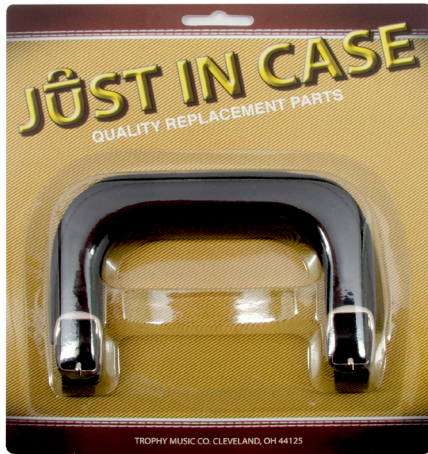

Quality Handles, Hinges, Locks and Corners are direct replacements for virtually all types and styles of cases. Attractive, colorful packaging is designed to get parts out of drawers and up on counters and walls where your customers can see them, "Just in Case" they need them.

No. CP60 Molded Handle



No. CP62 Center Bar Handle



No. CP64 Leather Emergency Handle Brown

No. CP66 Leather Emergency Handle Black



No. CP68 Leather Buckle Handle, Brown



No. CP70 Leather Buckle Handle, Black

BULK HANDLES

BUCKLE HANDLES - POST TYPE



Cowhide covered, with adjustable buckles. 5" spacing. Nickel-plated metal parts.

- No. 5596** - Black
- No. 5597** - Brown

EMERGENCY HANDLES



Emergency handle, solid leather. Adjustable buckles, nickel plated metal parts.

- No. 5563** Brown Pigskin Covered
- No. 5564** Black Pigskin Covered

TROPHY

JUST IN CASE HARDWARE

DRAWBOLTS



No. CP10 Small Drawbolt



No. CP12 Small Drawbolt, Deluxe



No. CP15 Large Drawbolt



No. CP17 Large Drawbolt, Deluxe

LOCKS



No. CP20 Small Lock, Deluxe



No. CP22 Large Lock, Deluxe

HINGE



No. CP40 Large Hinge

RUBBER BUMPERS



No. CP30 Rubber Bumpers, 4

MOUNTING HARDWARE



No. CP45 Wood Screws, 5

STEEL CONERS



No. CP32 Steel Corners, 4



No. CP46 Chrome Split Rivets, 5



No. CP47 Brass Split Rivets, 5

TROPHY BATONS

TROPHY “FIBERGLASS” BATON DISPLAY

Trophy® Batons are featherlite and perfectly balanced. This eye-catching baton display has an easel back for counter use and a hole at the top for a hanging display.



FIBERGLASS BATON DISPLAY (12 Batons)
No. 3870 One each of the individual batons below.



Natural Cork

Natural Birch Wood

INDIVIDUAL “FIBERGLASS” BATONS

- No. 3871** 14” Tapered cork handle
- No. 3872** 14” Tapered wood handle
- No. 3873** 14” Pearl shaped cork handle
- No. 3874** 14” Pearl shaped wood handle
- No. 3875** 16” Tapered cork handle
- No. 3876** 16” Tapered wood handle
- No. 3877** 16” Pearl shaped cork handle
- No. 3878** 16” Pearl shaped wood handle
- No. 3879** 18” Tapered cork handle
- No. 3880** 18” Tapered wood handle
- No. 3881** 18” Pearl shaped cork handle
- No. 3882** 18” Pearl shaped wood handle

MAESTRO LITE “Lite-Up” CONDUCTORS BATONS

Captivating your orchestra just became even more awe-inspiring with this illuminated conductors baton. Made of high quality Lexan™ these batons are light weight yet durable with long battery life. Batons also come with one set of replacement batteries. Just another great product from the Trophy Music Company.



No. TR7BW MAESTRO LITE “Lite-Up” CONDUCTORS BATONS

TROPHY BATONS

“MAESTRO” LEADER BATONS

Natural cork genuine black walnut

Maestro leader batons are perfect for lessons, learning, practice. American Birch with bright white shaft and come with either Pear-shaped, tapered, genuine black walnut or natural cork handles.

*Batons are sold separately or 12 Batons to a display.

Cork Handle Display (12 Batons)

No. TR2000 Individual Cork handles bright white painted shafts

- No. TR6B** 12” Tapered Handle
- No. TR11B** 12” Pear-shaped Handle
- *No. TR7B** 14” Tapered Handle
- *No. TR12B** 14” Pear-shaped Handle
- No. TR8B** 16” Tapered Handle
- No. TR13B** 16” Pear-shaped Handle
- No. TR9B** 18” Tapered Handle
- No. TR14B** 18” Pear-shaped Handle
- No. TR10B** 20” Tapered Handle
- No. TR15B** 20” Pear-shaped Handle

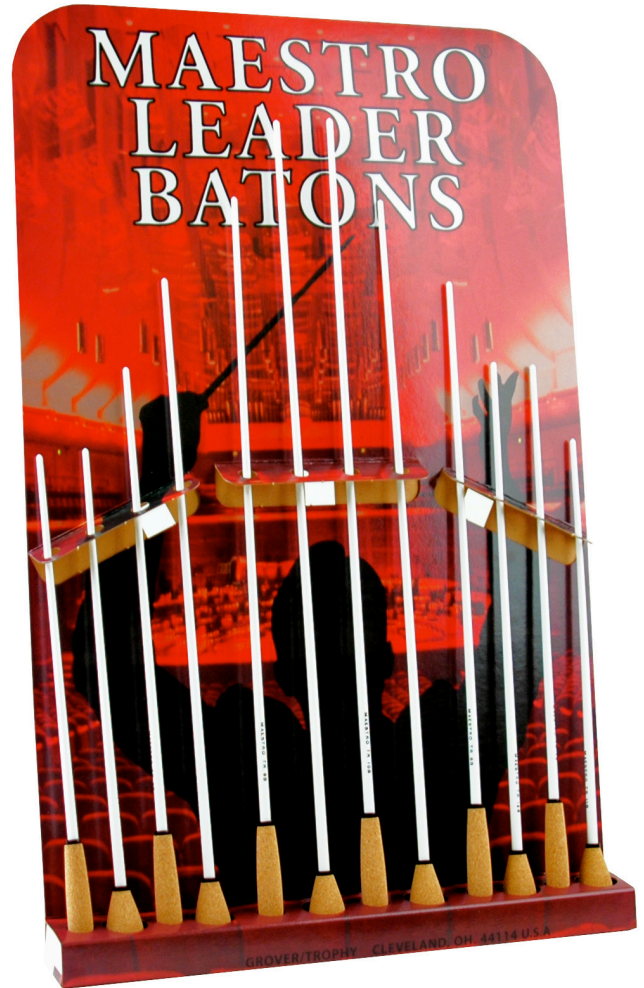

Walnut Handle Display (12 Batons)

No. TR2000W Individual Walnut handles bright white painted shafts

- No. TR6BW** 12” Tapered Handle
- No. TR11BW** 12” Pear-shaped Handle
- No. TR7BW** 14” Tapered Handle
- No. TR12BW** 14” Pear-shaped Handle
- *No. TR8BW** 16” Tapered Handle
- *No. TR13BW** 16” Pear-shaped Handle
- No. TR9BW** 18” Tapered Handle
- No. TR14BW** 18” Pear-shaped Handle
- No. TR10BW** 20” Tapered Handle
- No. TR15BW** 20” Pear-shaped Handle

* - Two batons per display

Eye catching store display holds 12 assorted batons.



Genuine Black Walnut

Natural Cork

**TROPHY
BATONS**

Conductor's Batons

SYMPHONY™

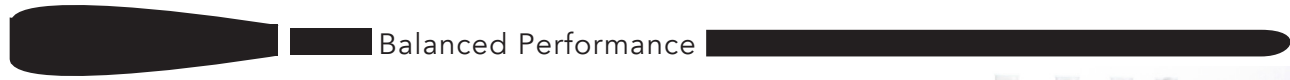

Our SYMPHONY BATONS are individually balanced within 2% accuracy for perfect feel. The balancing causes the weight of the batons to practically disappear.

SYMPHONY BATONS are available in a choice from five exotic wood handles. You may choose from Ziricote, Morado, Cocobolo, Bocate, Rosewood. Available in 12" or 14" overall lengths.

The display of eight batons consists of four 12" and four 14" batons, each with a different exotic wood handle.



Baton Display

No. TR2000EW

8 Batons On Display

INDIVIDUAL BATONS

White Shafts

- No. TR12EB** Baton 12" Bocate Handle
- No. TR14EB** Baton 14" Bocate Handle
- No. TR12EC** Baton 12" Cocobolo Handle
- No. TR14EC** Baton 14" Cocobolo Handle
- No. TR12EM** Baton 12" Morado Handle
- No. TR14EM** Baton 14" Morado Handle
- No. TR12ER** Baton 12" Rosewood Handle
- No. TR14ER** Baton 14" Rosewood Handle
- No. TR12EZ** Baton 12" Ziricote Handle
- No. TR14EZ** Baton 14" Ziricote Handle

Each baton is individually labeled with a description of it's handle.



Bocate Cocobolo Morado Ziricote

“ MAESTRO”



An outstanding presentation baton. The perfect gift for the Music educator. The shaft is a mirror polished, genuine rosewood with an equally beautiful ebony handle. Baton is mounted on a beautiful walnut base with sterling silver plaque for personal engraving.

No. TR100 Gift Baton

TROPHY STRING INSTRUMENTS

APPLECREEK™



Applecreek dulcimers have the perfect combination of excellent quality and affordable pricing to fit virtually all musical applications. Our dulcimers range from the ACD100 small body laminated spruce model, perfect for beginners, all the way up to our ACD200 Solid cherry wood model, suitable for the professional player. All Applecreek dulcimers are hand crafted in Europe and feature a 6 1/2 fret.

“TEARDROP” MODEL



Student “Teardrop” model. Natural laminated spruce top. Stained laminated spruce back and sides. Solid maple neck and fingerboard.

Total Length: 31”

Body Depth: 1 7/8”

Scale Length: 24”

No. ACD100 Student “Teardrop” Model

No. ACD100K As above with case

HOURLASS MODEL



Natural laminated spruce top. Stained laminated spruce back and sides. Solid maple neck and fingerboard.

Total Length: 37”

Body Depth: 2”

Scale Length: 27”

Lower Bout: 16 1/2”

Upper Bout: 13 1/4”

No. ACD150 Hourglass Model

No. ACD150K As above with case

CASE



CASE



Extremely durable nylon case features an accessory pocket and shoulder strap. Can be carried with handle like a suitcase or over the shoulder like a backpack.

No. AC50 Case

PRO MODEL



Solid cherry back, sides and neck.

Total Length: 37”

Body Depth: 2”

Scale Length: 27”

Lower Bout: 16 1/2”

Upper Bout: 13 1/4”

No. ACD200 Solid Cherry “Pro” Model

No. ACD200K As above with case

INSTRUCTION BOOK



Simply written, it contains 19 all time favorite songs. Anyone can learn to play.

No. ACB10 Instruction Book

All Applecreek dulcimers include a pick and noter, and are also available as an outfit.

TROPHY

STRING INSTRUMENTS

MELODY HARP®



The MELODY HARP® is truly one of the world's easiest and fun musical instruments to play! Simply slide a song sheet under the strings, fold down the "tab" to hold the music in place and follow the "dots" with your pick. In minutes anyone will sound like they've taken music lessons for years... IT'S THAT EASY! The MELODY HARP® is a highly-polished, wood-crafted instrument that everyone not only will have fun playing, but will be proud to own and display.

Lifetime String Guarantee! Should a string ever break, no matter what the reason, simply return the guarantee coupon along with a self-addressed stamped envelope and we will send you a new string ABSOLUTELY FREE, along with another coupon should one break again.

Heavy-duty String Posts! The Melody Harp® is designed with extra strong string posts. They will not bend under string pressure making it easier to tune and stay in tune.

Variety of Songs to Play! We have produced many song packets for you to purchase that will add to the enjoyment of owning a Melody Harp®. Music is printed on durable and easy-to-keep-clean glossy catalog cover stock.

Music and Words Together! What's more fun than just strumin' strings? Singing along with the music! So we print the words right on each music sheet... music and words together... nothing to lose!

Simple Connect-the-Dot Music! It's so easy to play, you don't have to read music. Our special "dot system" is easy for any age to understand. Simply connect the dots with your pick!

Unique "Tab" System! With our unique "tab" system, the music sheets are held in place allowing the player to position the instrument on their lap without the music falling off.



- No. FN600 Melody Harp
- No. FNPC Polishing Cloth
- No. FN6C Carrying Case

Polishing Cloth



Carrying Case



A Hunting We Will Go
A Tisket, A Tasket
Are You Sleeping
Baa Baa Black Sheep
Froggie Went a Courtin'
Hickory Dickory Dock
I'm a Little Teapot
Mary Had a Little Lamb
Polly Wolly Doodle
Pop Goes the Weasel
The Old Grey Mare
Where O Where Has My Little Dog Gone

No. MP-10 Children's Songs #1



Camptown Races
Dinah
Eensy Weensy Spider
It's Raining, It's Pouring
Jack and Jill
Mary, Mary Quite Contrary
Mulberry Bush
Row, Row, Row Your Boat
Skip To My Lou
Sweet Betsy From Pike
Ten Little Indians
Three Blind Mice

No. MP-15 Children's Songs #2



Blue Tail Fly
Buffalo Gals
Clementine
Cripple Creek
Down in the Valley
Drink To Me Only With Thine Eyes
I've Been Working on The Railroad
Little Brown Jug
Meet Me In St. Louis
While Strolling Through The Park
Turkey in the Straw
You Are My Sunshine

No. MP-25 Folk Songs #1



Auld Lang Syne
Blow the Man Down
Good Night Ladies
Happy Days are Here Again
Home on the Range
I Wish I Was Single Again
She'll be Comin Round the Mountain
Shenandoah
Shoo Fly
Swing Low Sweet Chariot
That Old Gang of Mine
When All the Works Done This Fall

No. MP-30 Folk Songs #2



Angels We Have Heard on High
Deck the Halls
Go Tell It On the Mountain
God Rest Ye Merry Gentlemen
Hark the Herald Angels Sing
Jingle Bells
Jolly Old St. Nick
Joy to the World
O Christmas Tree
O Come All Ye Faithful
Silent Night
The First Noel

No. MP-35 Christmas Songs #1



A Babe is Born in Bethlehem
Good King Wenceslas
Here we come a Caroling
The Holly and the Ivy
It came upon the Midnight Clear
O Come O Come Emmanuel
O Holy Night
Santa Claus is Coming to Town
Up on the House Top
We Three Kings
What Child is This
I Saw Three Ships

No. MP-40 Christmas Songs #2

TROPHY

STRING INSTRUMENTS

ALL WOOD UKULELE

Our soprano size Ukulele is made of solid woods and includes a pitchpipe for easy tuning and chord chart for instant learning. Steel gears and real metal frets add to this quality musical instruments.

DID YOU KNOW: That the word Ukulele (pronounced OOKALALE) means “jumping fleas” in Hawaiian. When the instrument was introduced to Hawaii by Portuguese travelers, the natives thought that their fingers looked like jumping fleas when they played!



INSTRUCTIONS INCLUDED

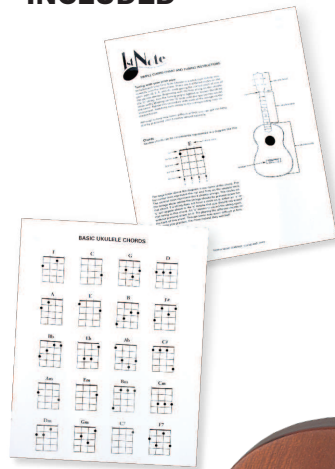

FOR AGES 5 AND UP.



No. **FN50** All Wood Ukulele
No. **FN28GB** Soft Bag

TROPHY

STRING ACCESSORIES

GUITAR ENDPINS



24 Chrome plated endpins in transparent display box. Includes screws.

No. 3431 Box of 24

ECONOMY GUITAR STRAPS



Brightly colored and durable 2" polypropylene guitar straps are fully adjustable. They feature tough "leatherette" tabs and include shoestring for easy attachment. Individually polybagged.

No. GS1BE Blue

No. GS1BK Black

No. GS1RD Red

PICKS



Made of the highest quality green felt. Extra large size is easy to hold. Best for uke and bass guitar.

No. 62G



Specially processed hard white felt. Beveled edge. Perfect for uke, guitar, banjo, and bass.

No. 2553/12 Oval

No. 2554/12 Pear

TROPHY

STRING ACCESSORIES

GUITAR BRIDGES

REGULAR FOR TAILPIECE



No. 3342 Hardwood, Ebonized. Notched, with white plastic saddle. For use on guitar with tailpiece.



No. 3348 Hardwood, Ebonized. Notched. German-silver fret. For guitar with tailpiece.

FOR CLASSIC GUITAR - PINLESS STYLE



No. 3323 Rosewood Glue-on Style. 7 inches wide. Bone saddle and recessed channel for ball-end strings. Beveled edges. Specially designed for classic style guitars.

ADJUSTABLE Simple, Easy To Adjust. For flat top guitars, using tailpieces.



No. 3380 Hardwood, Ebonized



No. 3381 Rosewood



No. 7919 Two piece ebony bridge. Fully adjustable 11/16" to 15/16" for archtop guitars.

TROPHY

VIOLA, CELLO and BASS ACCESSORIES

ROSINS

“PETZ” ROSIN

PETZ rosins are imported from Austria and are simply “the best rosin available”



VIOLIN

No. 5950 Round in Cloth



CELLO

No. 5951 Round in cloth



BASS

- No. 5982-2** Soft, cold climate
- No. 5982-3** Medium, moderate climate
- No. 5982-4** Hard, warm climate

“PAGANINI”™ ROSINS

ALL PAGANINI™ rosins are imported from Germany and are blended of the finest materials available. Packaged in a wide variety of styles to suit all tastes, PAGANINI™ is a registered trademark of Trophy Music Company.



VIOLIN

Good Quality

No. 5501 Cork book, light amber

Fine Quality

No. 5503 Boxed, w/cloth, medium amber

No. 5505 Boxed, w/cloth, light amber



CELLO

Fine Quality

No. 5536 Foam type cloth, light amber



No. 5537 Foam type cloth, dark amber

Best Quality

No. 5512 Boxed, all weather



BASS

Best Quality

No. 5513 Square cake, all weather

TROPHY

VIOLA, CELLO and BASS ACCESSORIES

PEGS

Fine Quality, Ebony



- No. 5656** Viola
- No. 5874** 4/4 Cello
- No. 5876** 3/4 Cello

BRIDGES

*Finest Quality Maple.
Imported from Germany*



- No. 5847** Bausch, 4/4 Cello
- No. 5848** Bausch, 3/4 Cello
- No. 5849** Bausch, 1/2 Cello

TAILPIECES

Fine Quality, Ebony



- No. 5657** Viola
- No. 5890** 3/4 Cello
- No. 5996** Bass (Violin Style)

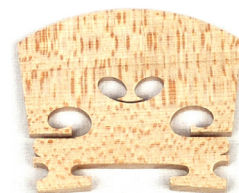

- No. 5651** Bausch, Viola

HUMIDIFIERS

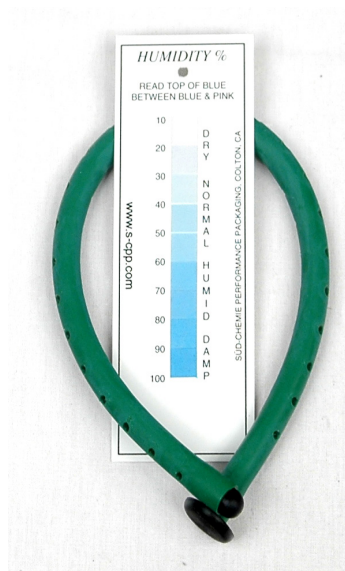

- No. 5898** Cello

NUTS

Fine Quality, Ebony



- No. 5892** Cello

SADDLES

Fine Quality, Ebony



- No. 5892** Cello

Protects fine instruments from cracking!
TROPHY HUMIDIFIERS are made of soft latex that is harmless to all instrument finishes. They release moisture to maintain a proper humidity level thus preventing fine instruments from cracking

- No. 5460** Violin or Viola
- No. 5860** Cello
- No. 5960** Bass

TROPHY

VIOLA, CELLO and BASS ACCESSORIES

STRING ADJUSTERS

All adjusters are bright nickel plated and have slotted hooks to accommodate loop or ball end strings.

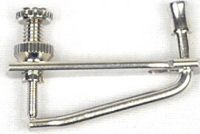

No. 3135 Viola, Post style

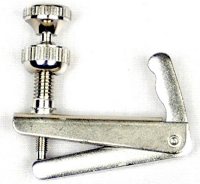

No. 3137 Viola, Hinged
No. 3024 Cello, Full size
No. 3025 Cello, Half size

SLIDING MUTES



No. TR3M Violin
No. TR4M Viola



No. TR5M Cello
No. TR6M Bass

EBONY MUTES



No. 5663 Viola
No. 5893 Cello

TOURTE MUTES



No. 5664 Viola, Round
No. 5894 Cello, Round
No. 5994 Bass, Round



No. 5895 Cello, Shaped

PAGANINI TAILGUT



Installs without tools! Adjustable to fit specific instruments. Won't wear or stretch. Soft as gut but will last 10 times longer.

No. 5468 Violin
No. 5468F Violin fits 1/16 -1/4 size
No. 5469 Viola
No. 5470 Cello
No. 5470F Cello fits 1/8 -1/4 size

TROPHY

VIOLA, CELLO and BASS ACCESSORIES

PAGANINI™

Bass and Cello End Pin Holders

These end pins holders are made from composite engineering plastic and a hybrid natural and butyl rubber.

The molded engineering plastic top is designed to hold the end pin in a deep cup that insures a positive hold. The material is break resistant for a long life.

The molded rubber bottom is made of two materials to combine durability and a sure grip. Ribbing is molded into the piece to improve the non-slip nature of the materials.

Life time guarantee. If a Paganini end pin holder breaks during normal use, return it to us and we will replace it at NO CHARGE.

Each end pin holder is packaged clam shell with a header card for easy display.



No. 4084 Cello



No. 4085 Bass

ENDPIN HOLDER

For Bass and Cello

Non-skid waffle pattern foam holder. Metal cap.



No. 4080 Bass



No. 4081 Cello

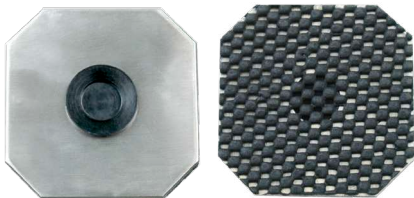

Our "Best" Endpin holder for cello and bass is made of indestructible stainless steel and is only ¼" thick for lightness and storability. Easily fit's in your pocket. It features an unique waffle pattern rubber bottom to firmly grip all surfaces.

No. 4090 Bass and Cello Endpin Holder

ENDPINS

Finest Quality. Imported.
Precision Made. Nickle Plated.



No. 5986 Bass, Ebonized Plug

TROPHY VIOLIN ACCESSORIES

EBONY VIOLIN PEGS



Imported. Good quality ebony.

No. 5448 Full size

No. 5449 3/4 size

No. 5450 1/2 size

“PETZ” ROSIN REMOVER



No. 5953 Rosin remover

“PAGANINI” VIOLIN POLISH



The finest cleaner and polish made. Provides a durable, natural coating to keep string instruments looking new longer.

No. 5500 1-oz. Bottle

EBONY VIOLIN NUTS AND SADDLES



Better Quality Imported Ebony. Per Dozen.

No. 5484 Nuts, unfinished

No. 5486 Saddles, unfinished

EBONY VIOLIN ENDPINS



No. 5481 Plain

“PAGANINI” SHOULDER RESTS



Standard Models

For Violin and Small Viola

Conforms perfectly to the contour of violin or viola, with a firm grip. The frame is made of unbreakable Duranite. The cushion part is of a special resilient material covered with velveteen. For full and 3/4 size Violins and 13” and 14” Violas.

Each is packaged in an attractive 2-color display box.

No. 3015 Shoulder Pad, Low

No. 3016 Shoulder Pad, High

TROPHY

VIOLIN ACCESSORIES

BRIDGES

All Violin Bridges are of Fine German Quality



TELLER

Good Quality Maple

No. 5400 4/4 size

No. 5401 3/4 size

No. 5402 1/2 size



TELLER

"E" Insert Fine Quality Flamed Maple

No. 5408 4/4 size

No. 5409 3/4 size

No. 5410 1/2 size



TELLER

Fitted Fine Quality Flamed Maple

No. 5405 4/4 size

No. 5406 3/4 size

No. 5407 1/2 size



TELLER

Fitted with "E" insert. Fine Quality Flamed Maple

No. 5465 4/4 size

No. 5466 3/4 size

No. 5467 1/2 size

VIOLIN CHINRESTS

"Bakelite"



No. 3013 "Leaf" Model



No. 3017 Deep Bowl, Ribbed Model

TROPHY

VIOLIN ACCESSORIES

SLIDING MUTE



Balanced muting on all four strings. Slides on and off without removing from instrument.

No. TR3M Sliding Mute

VIOLIN MUTE



No. 5281 Shaped Fine Ebony

TOURTE MUTES



Tourte mutes are molded in rubber. Excellent sound deadening qualities.

No. 5284 Round
No. 5285 Shaped

STRING ADJUSTERS



All adjusters are bright nickel plated and have slotted hook to accommodate loop or ball end strings.

No. 3020	Post style	4/4 and 3/4
No. 3124	Hinged	1/2 and 1/4
No. 3125	Hinged	4/4 and 3/4
No. 3130	Fractional	1/2 through 1/16

HUMIDIFIER

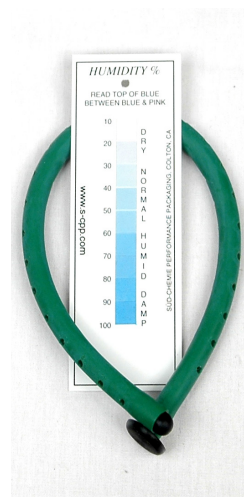

Protects instruments from cracking!

TROPHY Humidifiers are made of soft latex that is harmless to all instrument finishes. They release moisture to maintain a proper humidity level thus preventing fine instruments from cracking

No. 5460 Violin

ALL TYPES OF MUTES ARE ALSO AVAILABLE FOR VIOLA, CELLO, AND BASS

TROPHY NOVELTY

TROPHY CLASSICS

Trophy Classics are an outstanding collection of instruments that have enjoyed popularity for many, many years. From our Flutophone, introduced in 1943 and the first instrument to over 50,000,000 children, to the ever popular Jaw Harp which was carried in the pockets of many of our grandparents, Trophy Classics are sure to bring a lot of “I haven’t seen one of those in years” comments when displayed on your counter.



No. 3470
Musical
Spoons



No. 3471
Harmonica



No. 3472
Metal Kazoo



No. 3473
Jaw Harp



3474
Flutophone



No. 3475
Ocarina



No. 3477
Plastic
Kazoos



No. 3478
Slide Whistle

TROPHY NOVELTY

1stNOTE® NOVELTY INSTRUMENTS

HUM-A-ZOO



2" round kazoo is easy to play and perfect for parties.

No. FN100 1stNote Blister Card

NOSEFLUTE



The most fun, zaniest, best selling novelty in our line. Played by blowing air through the nose. Changing the shape of your mouth alters the sound. Great fun!

No. FN110 1stNote Blister Card

No. 8520 Bag of 12



Humor pack.

No. FN115 Humor Pack Blister Card

PLASTIC KAZOO

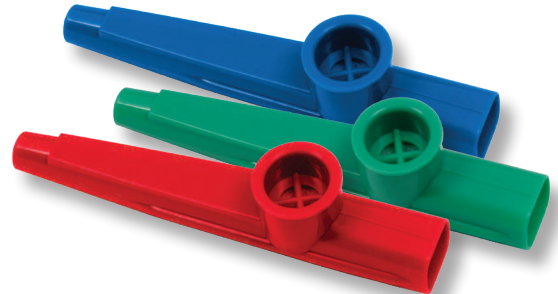

Our standard plastic submarine style kazoos are simply the best on the market today!

No. FN120 1stNote Blister Card

No. B120 Bulk Kazoo

METAL KAZOO

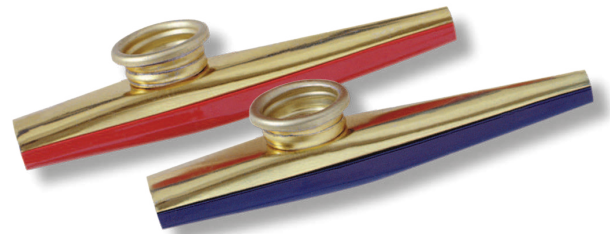

The "old standard" is back due to popular demand. Made as they were in the 1800's.

No. FN125 1stNote Blister Card

No. 701 Bulk Kazoo

No. 701B Individual Blister Card

MAGIC FLUTE

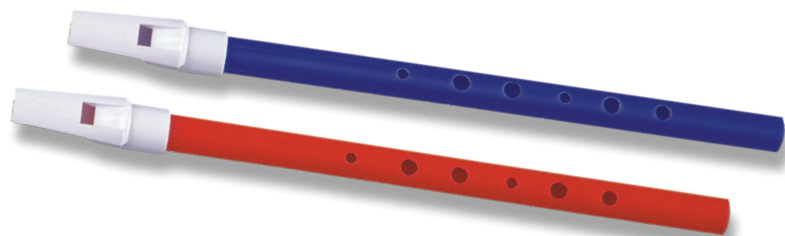

Easy to play wind instrument provides an excellent introduction to music. All of our wind instruments come with fingering charts and simple songs.

No. FN130 1stNote Blister Card

TROPHY NOVELTY

1stNOTE® NOVELTY INSTRUMENTS

DIXIE FIFE

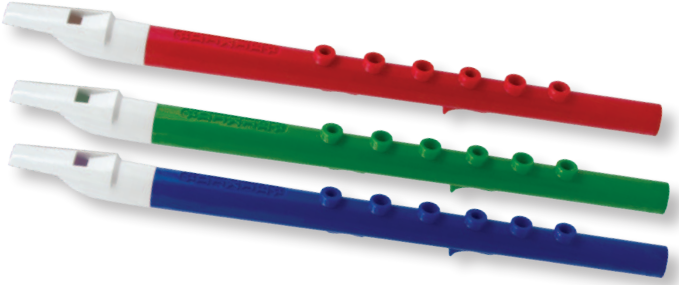

Similar to the FN130 but with raised finger-holes for even easier play.

No. FN140 1stNote Blister Card

HARMONICA



Excellent quality 10 holes (20 note) is perfect for the beginning player. The ideal model to accompany all instruction methods. Tuned to the key of C.

No. FN145 1stNote Blister Card

SLIDE WHISTLE



Unique instrument plays like a trombone. Play any song or use to create unusual sound effects.

No. FN150 1stNote Blister Card

OCARINA



Sometimes called a "Sweet Potato" this fun, musical instrument has been around for ages. Plays like a flute with simple fingering.

No. FN152 1stNote Blister Card

FLUTOPHONE®

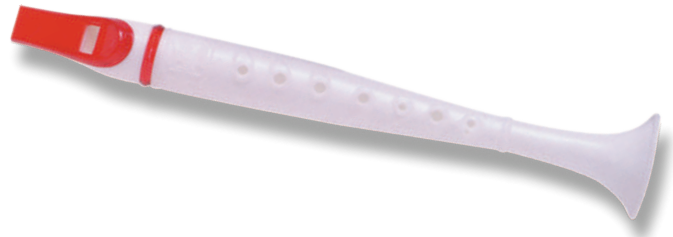

Over 35 million sold! The Flutophone is the easiest to play of all wind instruments and is used in thousands of classrooms across the country.

No. FN153 1stNote Blister Card

RECORDER



Used by more educators to introduce children to music than any other musical instrument in the world. Excellent quality, perfect for home or school use.

No. FN155 1stNote Blister Card

TROPHY NOVELTY

1stNOTE® NOVELTY INSTRUMENTS

MOUTH HARP



This ancient musical instrument is more popular than ever. Played by holding to mouth and striking the vibrating “tongue.” Creates all types of unusual sounds.

No. FN160 1stNote Blister Card

RHYTHM STICKS

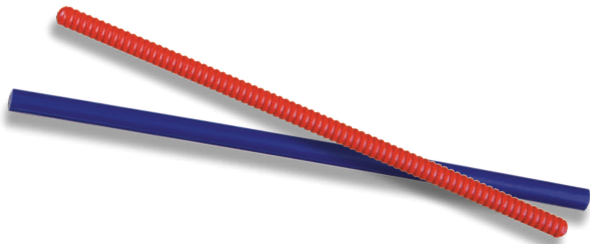

Played by striking or scraping together. Used to provide rhythm accompaniment for all music.

No. FN200 1stNote Blister Card

CASTANETS



Brightly colored castanets are played by “clicking” together between thumb and forefinger. Elastic cord makes them easy to hold for young hands.

No. FN205 1stNote Blister Card

EGG SHAKERS



We have added new packaging for our “TOP SELLING” Egg Shakers for better display with our other Firstnote products. Still the best selling Egg Shakers on the market!!!

No. FN206 1stNote Blister Card

MINI MARACAS



We have added new packaging for our “TOP SELLING” Maracas for better display with our other Firstnote products. Still the best selling Maracas on the market!!!

No. FN208 1stNote Blister Card

FINGER CYMBALS



Metal finger cymbals are played like castanets. Provides bell-like “chinging” sound.

No. FN210 1stNote Blister Card

TROPHY NOVELTY

1stNOTE® NOVELTY INSTRUMENTS

JINGLE STICK



Played by tapping against the palm of your hand. Nice “jingle” effect.

No. FN215 1stNote Blister Card

SAND BLOCKS



Hold in each hand and slide together, “swish-swish” sound.

No. FN225 1stNote Blister Card

CLUSTER BELLS



Brightly colored cluster bells provide a very nice, “soft” jingle effect.

No. FN218 1stNote Blister Card

WRIST & ANKLE BELLS



Brightly colored bells are quality made in the U.S.A. Easily attaches with Velcro® sewn into the band allowing bells to be used on any size wrist or ankle.

No. FN228 1stNote Blister Card

SLEIGH BELLS



The best quality sleigh bells available. 6 brightly plated bells provide that loud “jingle bells” sound.

No. FN220 1stNote Blister Card

TRIANGLE



Tuned triangle is made of special aluminum for crisp tone. Hit with striker for “chime” sound.

No. FN230 1stNote Blister Card

TROPHY NOVELTY

1stNOTE® NOVELTY INSTRUMENTS

MUSICAL SPOONS



Unique novelty instrument is actually two “spoons” connected in a specially designed handle. Easy to hold for any age.
No. FN232 1stNote Blister Card

TAMBOURINE



Very durable tambourine has an extra heavy duty head which is virtually impossible to break during normal play. Good, loud sound.
No. FN234 1stNote Box

MARCHING CYMBALS



Pair of 5-inch cymbals have specially contoured handles for young hands. Wonderful “crash” effect.
No. FN240 1stNote Blister Card

TONE BLOCK

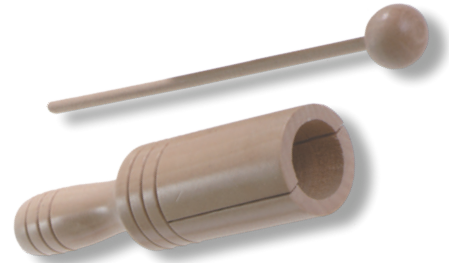

Solid wood tone block and mallet are used to provide a “hollow” wood tone.
No. FN242 1stNote Blister Card

CLAVES



Hardwood claves are manufactured in the U.S.A. Striking them together produces a sharp percussion accent.
No. FN248 1stNote Blister Card

MARACAS



Brightly colored maracas have extra filling for loud, authentic sound. Perfect for group play.
No. FN250 1stNote Box

TROPHY NOVELTY

NOVELTY WIND INSTRUMENTS

RIVER BOAT WHISTLE



Two tone whistle sounds just like a river boat. Individually bagged with header.

No. 4217 River Boat Whistle

SINGLE TRAIN WHISTLE



Has a real train sound with four distinct tones. 8" x 1-3/8" x 1-3/8". Individually bagged with header.

No. 4218 Single Train Whistle

SLIDE WHISTLE



Without a doubt the finest slide whistle in the world. The Trophy Slide Whistle is used in many commercial applications and in professional orchestras where a true glissando (trombone) effect is required. Brightly plated all metal construction it is entirely hand assembled for precision.

No. W10 Slide Whistle

TRANSPARENT SLIDE WHISTLE



Transparent slide whistle and all new packaging is designed to show children how sound works. The transparent tube allows children to visualize the chamber size changing as the sound changes.

Perfect for science projects.

No. FN330 Transparent Slide Whistle

BAGPIPE

From Pakistan



This is an authentic bagpipe, made for children, that plays just like the real thing. Nicely finished wood and 100% cotton plaid cloth gives it that "scottish" look. Recommended for children 12 and up.

No. W600

TROPHY NOVELTY

WHISTLES

(Acme) SIREN WHISTLE From England



This siren whistle is completely hand assembled in England and is the finest available. Used very often in orchestras and commercially wherever an authentic siren sound is needed.

No. 3763 Siren Whistle

(Acme) POLICE WHISTLE From England



Acme whistles are know to be the best. This brightly plated whistle is used by police departments and sports referees everywhere.

No. 3761 Acme "Junior" 2" Long

No. 3762 Acme "Standard" 2-1/4" Long

TROPHY NOVELTY

RHYTHM INSTRUMENTS

WASHBOARD TIE



Wait no more! Just wear our unique Washboard Tie and you'll always be ready to add to the fun.

You can use the included thimbles, or experiment making other sounds with spoons, keys, quarters, bottle openers, even a small whisk broom... then stroke, scrape, strum, and tap your Washboard Tie to amaze everyone with your cool rhythms.

The 24 gauge rippled stainless steel never needs tuning or ironing and compliments any fashion style.

No. TT10T Washboard Tie

MUSICAL WASHBOARD



Our "Old Fashioned" Musical Washboard is manufactured exclusively for us by a company who has continuously produced washboards since the mid - 1800's. A very unique rhythm instrument, it produces great sound effects for school music and country western bands. Includes 3 "child size" Thimbles for easy play.

No. FN75 Musical Washboard

No. FN85 Country Jamboree Set

TROPHY NOVELTY

THUNDER TUBES

Crazy sound effects. No batteries! Just a shake of your wrist! Create the sound of a thunder storm in the palm of your hand! Amazingly authentic, you won't believe it!

ROCKET SHIP



2-1/4" Wide x 7" Tall
16"- Long Spring
No. TT30RS Rocket Ship

STARRY NIGHT



2-1/4" Wide x 7" Tall
16"- Long Spring
No. TT30SN Starry Night

LIGHTENING



2-1/4" Wide x 7" Tall
16"- Long Spring
No. TT30L Lightening

TIE-DYE



2-1/4" Wide x 7" Tall
16"- Long Spring
No. TT30TD Tie-Dye

BIG LIGHTENING



6" Wide x 6" Tall
34"- Long Spring
No. TT30BL Big Lightening

TROPHY NOVELTY

FIRESTIX®

The world famous LED Firestix™ flash with each strike. Made from lexan makes the Firestix™ perfect for children and amateurs but durable enough for professionals. **Light up the stage!**



No. FX12BL
Brilliant
Blue

No. FX12RD
Radiant
Red

No. FX12GR
Screamin'
Green

No. FX12CC
Color
Change
(13 Colors in one)

No. FX12PR
Purple Haze

No. FX12OR
Mango Tango

**TROPHY
NOVELTY**

MAROCKAS™

“SHAKE SENSITIVE” LED LIGHT-UP MaRockKas!

3 Colors-In-One **PLUS** 7 Color-Change Party Mode!

Maracas, sometimes called rumba shakers, chac-chacs or in our case MaRockKas, are rattles which appear in many genres of music. Our MaRockKas, however, are unique in that they LIGHT-UP! MaRockKas are designed with a sensor that allows them to glow brighter the harder you shake'em. Use the “FUN” button to change colors (Red, Green, Blue, PLUS 7 Color-Change Party Mode) and start “Shakin” today!



No. 5002 MaRockKas

TROPHY NOVELTY

BEADBRAIN SKULL SHAKERS

Beadbrain™ skull shakers are so much fun to play, it's scary! these “mini-maracas” are used in all styles of music and are perfect for professionals and students alike. Size 2.28” x 1.69” x 2.50”



No. BBSR Red



No. BBSBL Black



No. BBSBE Blue



No. BBSB Bone



No. BBSGL Glow



No. BBSPR Purple



No. BBSG Green



No. BBSO Orange

SHAKER BLOCKS

Shaker Blocks... Authentic reproductions of the old wooden “classic alphabet blocks” only made of durable ABS plastic.

Graded 0+ and brightly colored, Shaker Blocks are great “baby rattles”... and their true maraca sound makes them the perfect percussion accessory for school age kids... even adults!

Shaker Blocks contain the letters A-D and the numbers 1-4.

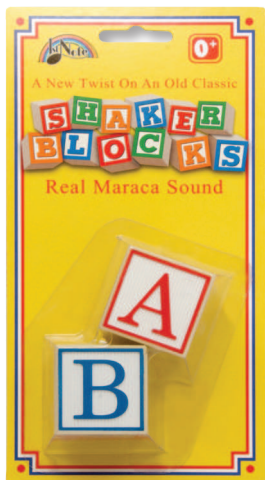

No. FN722 Blister Card Containing 2 Blocks

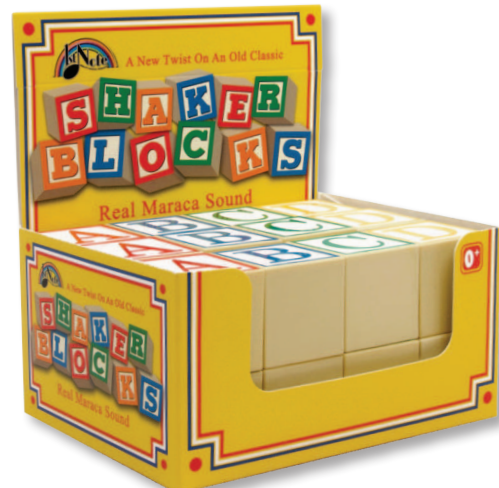

No. FN724 Counter Display 24pcs

TROPHY NOVELTY

RAINSTICKS Made in the USA



Our Tropical Rain sticks are a full 16" long and provide a gentle and soothing rain sound reminiscent of a tropical forest.

Specially designed internal baffles provide a soft, lingering sound usually found in much longer rain sticks.

Packaged in a beautiful Tropical design box. Trophy Music Co. will make a donation to the WWF for each Rain stick sold.

Available in 5 Bright colors:

- No. RS10** Canary Yellow
- No. RS12** Rainforest Green
- No. RS14** Kiwi Lime Green
- No. RS16** Mango Tango
- No. RS108** Wild Cherry

TROPHY DISPLAYS

1stNOTE® DISPLAYS

Our new colorful counter displays take less than 1/2 square foot of counter space yet are sure to generate DOLLARS!

The clean, "Classic" look of our new display is reminiscent of simpler times and reflects the almost 100 year history of our company.

All products are available in "bulk form" or individually sealed in poly bags with barcodes.

PLASTIC KAZOOS



- No. 8450** Display contains 50pcs Bulk
- No. 12050** Display contains 40pcs Bagged

EGG SHAKERS



- No. 10020** Display contains 50pcs Bulk

METAL KAZOOS



- No. 12550** Display contains 40pcs Bagged

MINI MARACAS



- No. 10024** Display contains 35pcs Bulk

SLIDE WHISTLES



- No. 10015** Display contains 30pcs Bulk

HUM-A-ZOO



- No. 10072** Display contains 75pcs Bagged

TROPHY DISPLAYS

1stNOTE® DISPLAYS

NOSEFLUTE



No. 11072 Display contains 75pcs
Bagged

WRIST & ANKLE BELLS



No. 12842 Display contains 25pcs
Bulk

LIP WHISTLE DISPLAY



No. 13072 Display contains 72pcs
Bagged

TROPHY CLASSICS DISPLAY



Trophy Classics are an outstanding collection of instruments that have enjoyed popularity for many, many years. From our Flutophone, introduced in 1943 and the first instrument to over 50,000,000 children, to the ever popular Jaw Harp which was carried in the pockets of many of our grandparents, Trophy Classics are sure to bring a lot of “I haven’t seen one of those in years” comments when displayed on your counter.

No. 3476 Trophy Classics Countertop
Display

TROPHY DISPLAYS

BEADBRAIN SKULL SHAKER DISPLAYS

Beadbrain™ skull shakers are so much fun to play, it's scary! these “mini-maracas” are used in all styles of music and are perfect for professionals and students alike. Size 2.28” x 1.69” x 2.50”

GLOW IN-THE DARK DISPLAY



No. **BB12G** Glow in-the Dark display

ASSORTED COLOR DISPLAY



No. **BB12A** Assorted color display

HALLOWEEN DISPLAY



No. **BB12WH** Halloween display

TUB DISPLAYS



No. **BB24A** 24 sealed plastic skulls.
Assorted color display

No. **BB24C** 24 sealed plastic Glow-in-the-Dark skull display

TROPHY DISPLAYS

EGG SHAKER DISPLAYS

SHAKIN' EGGS



24 high-quality “eggs” are packaged in a brightly colored counter display. These “mini-maracas” are used in all styles of music and produce that commonly heard swish-swish sound.

No. 14024 Shakin' Eggs

JUMBO SHAKIN' EGGS



1stNote® Jumbo Shakin' Eggs. Sold individually or in a 12ct. counter display. Our new, high quality, Jumbo Shakin' Eggs are slightly larger than our original Shakin' Eggs to allow for a 0+ rating. These “mini-maracas” are used in all styles of music and are perfect for students and professionals alike. They even make for great baby rattles. Get yours today!

No. 14026 12ct. Egg Display

TROPHY DISPLAYS

CIRCUS TIME SLIDE WHISTLE DISPLAY



Contains 12 of the finest quality plastic slide whistles available. Brightly colored and extremely durable TROPHY slide whistles are the easiest of all novelty instruments to play. Simply blow in the mouthpiece and move the slide to produce an amazing glissando (trombone) effect. Brightly colored display card can be hung on wall or built-in easel for counter display.

No. 30C Display of 12

FIFE DISPLAY



Bright assorted colors, easy to play, accurately tuned and educational all add up to make this one of our better sellers. Two full octaves! Includes fingering chart.

No. P28 Display of 24

TRAIN WHISTLE DISPLAY



12 authentic sounding train whistles in a 6"x 8" counter display and individually wrapped.

No. 4219 Train Whistle Display

TROPHY DISPLAYS

“SNOOPY” JAW HARPS



Patterned after the original American Jaw Harp. Sturdy, deluxe chrome-plated instrument has a tongue of specially tempered steel. Precision tuned to meet professional requirements. Individually boxed with “How to Play” instructions. 12 Jaw Harps attractively packaged in colorful display box.

No. 3490 Snoopy Jaw Harps

“OZARK” JAW HARPS

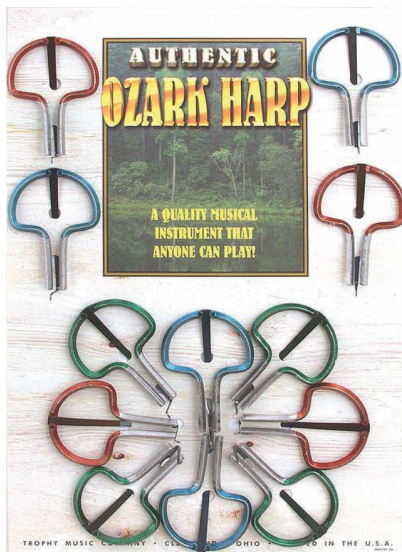

12 Jaw Harps on Display Card.

Lacquered steel frame, Swedish blue steel tonque with plastic ball on end. Display is packaged in cardboard box.

No. 3485 “Ozark” Jaw Harps

“BLUE GRASS” JAW HARPS



Nickel Plated

Made of the highest quality level steel with spring steel tongue. Individually hand-tuned for authentic voicing and clear resonant tone. 12 harps per counter display box. Individually packaged with “How to Play” instructions.

No. 8037 “Blue Grass” Jaw Harps



For three decades, The Cleveland Drum Company® has been producing mallets used by professionals around the world. Handmade using premium materials and digitally matched for weight and diameter, **there is no substitute for unrivaled Cleveland quality.**

THE CLEVELANDER DRUM COMPANY®

MALLETS

SYMPHONIC SERIES

Premium Mallets.

Symphonic Series, Percussion Mallets are available wound in cord or yarn and on a Birch or Rattan shafts. The yarn mallets are hand wound and sewn with 4-ply acrylic wool over a unique grooved core. The heads are 1 3/8" in diameter. The cord mallets are tightly wound with #10 100% cotton cord. The head diameter is 1".

MARIMBA

Acrylic yarn with birch shafts, 13- 3/4" overall length size. PAIR

No. **CSM1 (3220)** Soft- Tan

No. **CSM2 (3221)** Medium- Blue

No. **CSM3 (3222)** Hard- Black



VIBRAPHONE

Cotton cord with rattan shafts, 15- 1/4" overall length size. PAIR

No. **CSV1 (3223)** Soft- Yellow

No. **CSV2 (3224)** Medium- Blue

No. **CSV3 (3228)** Hard- Red

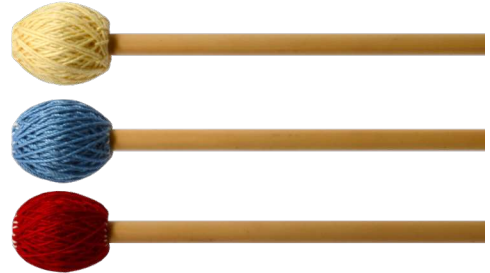

XYLOPHONE

Rubber or hard plastic beaters with birch shafts, 15" overall length size. PAIR

No. **CSX1 (3225)** Soft- Grey

No. **CSX2 (3227)** Medium- Pink

No. **CSX3 (3226)** Hard- Black

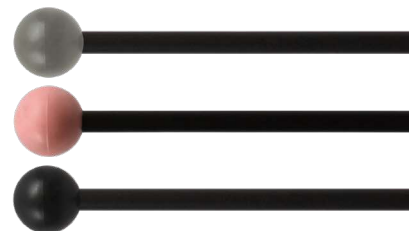

Rubber or hard plastic beaters with rattan shafts, 15" overall length size. PAIR

No. **CSX1R** Soft- Dark Grey

No. **CSX2R** Medium- Pink

No. **CSX3R** Hard- Light Grey

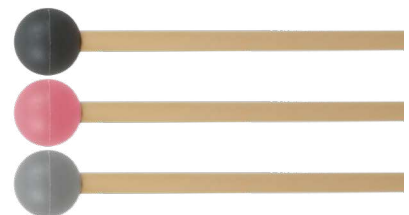

BELLS/GLOCKENSPIEL

Brass or acrylic beater heads and birch shafts, 12" overall length size. PAIR

No. **CSG1 (3170)** 1" diameter, polycarbonate heads

No. **CSG2 (3175)** 3/4" diameter, brass heads



MALLETS

SYMPHONIC SERIES

Premium Mallets.

Clevelander Timpani Sticks produce clear, focused, ringing sounds that project pure pitch and rich tone. Handmade with jointless bamboo handles, Clevelander sticks are truly the finest sounding timpani sticks available.

TIMPANI

“Staccato,” medium sized wood core

No. CD-B1



“Ultra Hard,” adhesive felt wrapped around felt core.

No. CD-B2



“Small Classic Ball,” a general type of stick with attack, seamless German felt over small wood core.

No. CD-B3



“Medium Classic Ball,” a general use mallet, German seamless felt over medium wood core.

No. CD-B4



“Large Classic Ball,” seamless German felt over large wood core for legato passages and rolls.

No. CD-B5



“Large Cartwheel,” hand-sewn German felt surrounding a felt core. Good for rolls

No. CD-B6



“Medium Cartwheel,” hand-sewn German felt surrounding a felt core.

No. CD-B7



“Small Cartwheel,” hand-sewn German felt surrounding a felt core. Very articulate

No. CD-B8



“Roller-ball,” a mallet for rolling, seamless German felt over felt core.

No. CD-B9



***Bamboo handles are digitally matched for weight and diameter**

THE CLEVELANDER DRUM COMPANY®

MALLETS

CONCERT SERIES

Designed for middle and high school music programs, the Concert Series offers exceptional playability and affordability.

MARIMBA

Acrylic yarn with delrin (feels like rattan) shafts, 15- 3/4" overall length size. PAIR

No. CCM1 (3253) Soft- Yellow



No. CCM2 (3254) Medium- Blue



No. CCM3 (3255) Hard- Black



VIBRAPHONE

Cotton cord with delrin shafts, 15- 3/4" overall length size. PAIR

No. CCV1 (3256) Soft- Yellow



No. CCV2 (3257) Medium- Blue



No. CCV3 (3258) Hard- Black



TIMPANI

Natural cherry shafts with German felt on ball models, 15- 1/2" overall length size. PAIR

No. CCT1 NEW Small ball



No. CCT2 NEW Medium ball



No. CCT3 (3052) Large ball



No. CCT4 (3051) Solid felt ball



BASS DRUM

Varnished hard wood with cork head wrapped in synthetic pyle to simulate lamb's wool

No. CCB1 (3035) Single end, 15" overall, 3" head.



No. CCB2 (3037)
Double end, 15- 1/2" overall,
3" top head, 2" bottom head.



THE CLEVELANDER DRUM COMPANY®

MALLETS

MARCHING (Drum Corps) SERIES

A great new line of mallets designed for Marching Bands.

BASS DRUM MALLETS

Aluminum Shafts, Felt Heads

Clevelander Mallets are provided with a hard felt head epoxied on a thick-walled, black satin, aluminum shaft. The shaft has a black, wooden, contoured end piece for comfort and non-slip rubber grip. PAIR

No. CMB1 (3150) 1- 1/2" diameter x 1- 1/4", 13-1/2" overall length size



No. CMB2 (3151) 2" diameter x 1- 1/2", 13-7/8" overall length size



No. CMB3 (3152) 2 1/2" diameter x 1- 3/4", 14-1/8" overall length size



HARDWOOD SHAFTS

Seasoned hardwood shafts with a clear, lacquer finish are epoxied to hard, felt heads. Each mallet is equipped with a natural finish, wooden, contoured end piece and non-slip rubber grip. PAIR

No. CMB4 (3155) 1- 1/2" diameter x 1- 1/4", 13- 7/8" overall length size



No. CMB5 (3156) 2" diameter x 1- 1/2", 14- 1/8" overall length size



No. CMB6 (3157) 2 1/2" diameter x 1- 3/4", 14- 3/8" overall length size



TIMP-TOM MALLETS

Aluminum Shafts

Each pair of Timp-Tom Mallets comes with a thick-walled aluminum shaft in black satin finish. The mallets are provided with an assortment of heads to fit various playing requirements. Each head provides a different sound. The aluminum shaft has a vinyl, non-slip grip. PAIR

No. CMT1 (3161) 1- 3/4" seamless hand-sewn heads, 15- 3/4" overall length size



No. CMT2 (3162) 1- 1/4" diameter, rubber heads, 15- 3/8" overall length size



No. CMT3 (3163) 1- 1/4" diameter, polycarbonate heads, 15- 1/4" overall length size



PARADE SERIES

BASS DRUM MALLETS

Seasoned hardwood shafts with a clear, lacquer finish are epoxied to cork heads cover in synthetic pyle. Each mallet is equipped with leather strap, great for pipe-band use.

No. CMB9 (3036) Single end, Leather loop. 15" overall, 3" head



TENOR MALLETS

Seasoned hardwood shafts with a clear, lacquer finish are epoxied to cork heads cover in synthetic Pyle. Each mallet is equipped with leather straps, great for pipe-band use.

No. CMT4 (3048) High grade solid white felt ball, leather thongs. 12" overall, 1- 3/4" head, PAIR



No. CMT5 Synthetic pyle over solid felt ball, leather thongs. 12" overall, 1- 3/4" head, PAIR



CLEVELANDER

MALLET BAG



Clevelander's Mallet Bag is perfect for students and professionals alike. The CDMB is a high quality, padded mallet bag, equipped with 3 internal pouches and 1 external, along with a hook-and-strap system and a reenforced ID holder on the back. The CDMB comes with a pair of CSX2 and CSX3 mallets for xylophone. A pair of CSM2 mallets for Marimba, a of CCT2 for Timpani and a pair of 5B drumsticks.

No. CDMB Mallet Bag

COWBELLS

Clevelander Cowbells offer clear tonality in a durable design and are a addition to your kit.



No. CB45 4.5" Tall

No. CB55 5.5" Tall

No. CB65 6.5" Tall

THE CLEVELANDER DRUM COMPANY®

TEMPLE BLOCKS



TEMPLE BLOCKS

Set of 5 high quality Temple Blocks. Beautiful, natural wood laminate for great tone and durability. Satin lacquer finished. Includes adjustable chrome plated stand and a pair of drumsticks.

No. CD-TB5

INDEX

B			
Bagpipes.....	108		
Banjo Bridges.....	25		
Banjo Tuning Keys/Pegs.....	18-19		
Banjo Wrench, Dual Bracket.....	29		
Bass Drum Anchor.....	68		
Bass Drum Rack.....	69		
Bass Drum Spur Holder.....	64		
Bass Guitar Picks.....	93		
Bass Guitar Tuners.....	15		
Batons			
Fiberglass	86		
Maestro.....	87		
Maestro “Lite-Up”.....	86		
Symphony.....	88		
Baton Displays			
Fiberglass	86		
Maestro.....	87		
Symphony.....	88		
Beadbrain Skull Shakers.....	114		
Beadbrain Skull Shakers Displays.....	118		
Bells			
Cluster	58, 106		
Rhythm Bells.....	58		
Sleigh Bells.....	57, 106		
Swiss Melodee Bells.....	58		
Trapeze Bells.....	57		
Wrist/Ankle Bells.....	57, 106		
Bell Sets			
8-Note Bell Set.....	59		
Chromatic Bell Sets.....	59, 61		
“Deluxe” Handbell Set.....	58		
Diatonic Sets.....	60		
Resonator Bell Sets.....	62		
Bell Step Ladder.....	62		
Bodhrans.....	49		
Bongos.....	48		
Bongos Stand.....	69		
Bore Cleaners.....	79		
Bridges			
Banjo Bridges.....	25		
Cello Bridges.....	96		
Guitar Bridges.....	23		
Mandolin Bridges.....	24		
Tremolo Bridges.....	29		
Viola Bridges.....	96		
Violin Bridges.....	100		
Bridge Saddles.....	30		
Brushes.....	79		
		C	
		Cable	
		Guitar/Instrument.....	26
		Microphone.....	26
		Speaker.....	26
		Capos.....	28
		Castanets	
		Castanets on a Holder.....	52
		Handle Castanet.....	52
		Plastic Castanet.....	52, 105
		Cello Nuts.....	96
		Cello Saddles.....	96
		Classroom Method Book.....	16
		Claves.....	53, 107
		Cleaning Cloth.....	80
		Cleaning Rod, Flute.....	80
		Cleaning Rod, Recorder.....	40
		Collar Replacements.....	82
		Conga Drums.....	47
		Conga Drums, Mini.....	47
		Cork Grease.....	80
		Cork Sheets.....	81
		Cowbells.....	128
		Cowbell Holder.....	68
		Cymbals.....	51
		Cymbal Holders.....	71
		Cymbal Pads.....	70, 71
		Cymbal Pads & Straps.....	70
		Cymbal Sleeve.....	64
		Cymbal Straps.....	71
		Cymbal Stand.....	69
		Cymbal Stand Wing Nut.....	64
		Cymbal Straps.....	71
		Cymbal Washers.....	64
		D	
		Dixie Fife.....	104
		Displays	
		Beadbrain Skull Shakers Displ.....	118
		Egg Shakers Displays.....	116, 119
		FeaDog Whistle Display.....	39
		Fife Display.....	120
		Hum-A-Zoo Display.....	116
		Jaw Harp Displays.....	102, 121
		Lip Whistle Display.....	117
		Metal Kazoo Display.....	116
		Mini Maracas Display.....	116
		NoseFlute Display.....	117
		Plastic Kazoo Display.....	116
		Slide Whistle Displays.....	116, 120
		Wrist/Ankle Bells Display.....	117
		Train Whistles Display.....	120
		Trophy Classics Display.....	117
		Drawbolts.....	85
		Drum Brushes.....	65
		Drum Clinic.....	63
		Drum Keys.....	64
		Drum Pedal Beaters.....	66
		Drum Pedal Replacement Strap.....	66
		Drum Slings.....	70
		Dulcimers	
		Teardrop Model.....	89
		Hourglass Model.....	89
		Pro Model.....	89
		Dulcimer Cases.....	89
		Dulcimer Instruction Book.....	89
		Dulcimer Pegs.....	22
		E	
		Egg Shakers.....	56, 105
		Egg Shakers Displays.....	116, 119
		End Pins	
		Bass.....	98
		Ebony.....	30
		Guitar.....	93
		Plastic.....	30
		Replacements.....	27
		End Pin Holders, Bass & Cello.....	98
		End Pin Tray.....	30
		End Plugs, Saxophone.....	77
		F	
		Finger Cymbals.....	51, 105
		FireStix.....	112
		Flip Folder.....	74
		Flip Folder Rings.....	74
		Flip Folder Windows.....	74
		Flute Head Corks.....	81
		Flutophone.....	36, 102, 104
		Flutophone Music Books.....	38
		Frame Drums.....	49
		G	
		Grover Finishes & Specs.....	4
		Grover Locking String Instruc.....	8
		Guitar Humidifier.....	27
		Guitar Bridges.....	23, 29, 94
		Guitar Picks.....	93
		Guitar Straps.....	93

INDEX

Guitar Tuning Keys

Bass.....	15
Locking Rotomatics.....	9, 10
Locking Vintage.....	11
Pedal Steel & Classic Guitar.....	16
Rotomatics.....	5 - 7
Tenor.....	21
Vintage.....	12, 13

H

Handles for Cases.....	84
Hand Drum.....	46
Hand Held Tom Tom.....	46
Hand Held Wood Block.....	44
Harmonica.....	102, 104
Harmonica Holder.....	40
Head Saver Pad.....	64
Hi-Hat Clutch.....	68
Hinges.....	85
Humidifiers.....	96, 101
Hum-A-Zoos.....	103
Hum-A-Zoo Display.....	116

I

Irish Penny Whistles.....	39
---------------------------	----

J

Jaw Harp.....	54, 102
---------------	---------

Jaw Harp Displays

“Bluegrass” Jaw Harps.....	121
“Ozark” Jaw Harps.....	121
“Snoopy” Jaw Harps.....	121
Jingle Clogs.....	58
Jingle Sticks.....	106
Jingles, Tambourine.....	50

K

Kazoos

Plastic.....	102, 103
Metal.....	102, 103

L

Leg Rest.....	70
Ligatures.....	77
Lip Whistle Display.....	117
Locks.....	85

Lyres

Baritone.....	75
Clairient.....	75
Flute/Piccolo.....	75
Saxophone.....	75
Sousaphone.....	75
Trombone.....	75
Trumpet.....	75

M

Magic Fife.....	103
-----------------	-----

Maintenance Kits

Clarinet (Composition).....	78
Clarinet (Wood).....	78
Flute.....	78
Saxophone.....	78
Trombone.....	78
Trumpet/Cornet.....	78

Mallets

Bass Drum.....	126-127
“Economy” Xylophone Mallets.....	65
Bell/Glockenspiel.....	124
Marching.....	127
Marimba.....	124, 126
“Nylo-Tex” Bell Lyre Mallets.....	65
“Saftey Mallets”.....	65
Parade.....	127
Tenor.....	127
Timpanis.....	125, 126
Timp-Tom.....	127
Vibraphone.....	124, 126
Xylophone.....	124

Mallet Bag.....	128
-----------------	-----

Mandolin Tuning Keys.....	17
---------------------------	----

Maracas.....	53, 107
--------------	---------

MaRockKas.....	113
----------------	-----

Marching Cymbals.....	107
-----------------------	-----

Mel-O-Dee Balls™.....	41
-----------------------	----

Melody Harp.....	90
------------------	----

Melody Harp Bag.....	90
----------------------	----

Melody Harp Music.....	91
------------------------	----

Melody Harp Polishing Cloth.....	90
----------------------------------	----

Mini Maracas.....	55, 105
-------------------	---------

Mini Maracas Display.....	116
---------------------------	-----

Mounting Hardware.....	85
------------------------	----

Mouth Harp.....	105
-----------------	-----

MouthPieces

Alto Sax.....	76
Clarinet.....	76
Tenor Sax.....	76

MouthPiece Caps

Alto Sax.....	76
Clarinet.....	76
Metal.....	77
Plastic.....	77
Tenor Sax.....	76

MouthPiece Puller.....	82
------------------------	----

Replacement Collars.....	82
--------------------------	----

MouthPiece Sets.....	76
----------------------	----

Music Clips, Long.....	81
------------------------	----

Music Desk Stand.....	40
-----------------------	----

Music Stand Bag.....	82
----------------------	----

Music Stand Lamp.....	83
-----------------------	----

Music-Time Method Book.....	38
-----------------------------	----

Musical Rhythm Sets.....	41
--------------------------	----

Musical Spoons.....	102, 107
---------------------	----------

Musical Therapy Kit.....	43
--------------------------	----

Musical Washboard.....	110
------------------------	-----

Musical Washboard Tie.....	110
----------------------------	-----

Mutes

Bass.....	97
Cello.....	97
Viola.....	97
Violin.....	97, 101

N

NoseFlute.....	103
----------------	-----

NoseFlute Display.....	117
------------------------	-----

O

Ocarina.....	102, 104
--------------	----------

Oils

Bore Oil.....	80
Key Oil.....	80
Super Oil.....	80

P

Part Trays

Plastic Bridge/End Pins.....	30
Nuts Assortment.....	30
Saddle Assortment.....	30

Pegs

Dulcimer Pegs.....	22
Cello.....	96
Viola.....	96
Violin Pegs.....	22, 99

Penny Whistle.....	39
--------------------	----

Perfect Nut.....	28
------------------	----

Polish Cloth.....	80
-------------------	----

Practice Pads.....	66
--------------------	----

R

Rainsticks.....	115
-----------------	-----

Ratchet.....	45
--------------	----

Recorders

1stNote.....	35, 104
Cambridge.....	36
Candy Apples by Tudor.....	34
Tudor.....	32-33

INDEX

Recorder Bag.....	40	Swabs	Ukulele Tuning Keys	20-21
Recorder Music Book.....	38	Clarinet.....	V	
Replacement Light Bulb.....	83	Recorder.....	Valve Protector.....	82
Rhythm Gourds.....	45	Saxophone.....	Vibraphone Mallets.....	124, 126
Rhythm Kits		Woodwinds.....	Violin Chinrests.....	100
Deluxe Kits.....	42	T	Violin End Pins.....	99
Economy Kits.....	42	Tailpieces.....	Violin Bridges.....	100
Musical Rhythm Sets.....	43	Tailgut, Paganini.....	Violin Humidifier.....	101
Musical Therapy Kit.....	43	Tambourines	Violin Mutes.....	97, 101
Rhythm Sticks.....	52, 105	Fish.....	Violin Pegs.....	22, 99
River Boat Whistle.....	108	Headless.....	Violin Polish.....	99
Rosin		Replacment Jingles.....	Violin Nuts & Saddles.....	99
Rosin, Paganini.....	95	Plastic Shell.....	W	
Rosin, Petz.....	95	W/ Skin Heads.....	Washboard, Musical.....	110
Rosin Remover.....	99	Tambourine.....	Washboard Tie.....	110
Rubber Bumpers.....	85	Talking Drums.....	Whistles	
Rubber Tips.....	64	Tap-Tap Blocks.....	Police Whistle.....	109
S		Taracas.....	Siren Whistle.....	109
Saddles.....	96	Tenor Guitar Tuners.....	Wood Block Holder.....	68
Sand Blocks.....	45, 106	Tension Rods.....	Wood Block & Cowbell Holder.....	68
Saxophone, End Plugs.....	77	Thumb-eez.....	Wood Block “Pro”.....	44
Saxophone Maint. Kit.....	78	Thunder Tubes.....	Woodwind Swabs.....	79
Shaker Blocks.....	114	Temple Block.....	Woodwind Straps.....	82
Shoulder Rest, “Paganini”.....	99	Tom Boy.....	Wool Pads.....	70, 71
Siren Whistle.....	109	Tone Blocks.....	Wrist/Ankle Bells.....	57, 106, 117
Slap Sticks.....	52	Tone Drums.....	X	
Sleigh Bells.....	57, 106	Tourte Mutes.....	Xylophones.....	59
Slide Grease.....	80	Train Whistles.....		
Slide Whistles.....	102,104,108,116,120	Train Whistles Display.....		
Snappy Snare.....	67	Trapeeze Bells.....		
Snappy Snare Strings.....	67	Trapeeze Jingles.....		
Snare Boy.....	46	Tremolo Bridge.....		
Snare Strainer.....	67	Triangle.....		
“Snoopy” Jaw Harp.....	121	Triangles, Aluminum.....		
Speaker Cables.....	26	Triangles, Steel.....		
Spinning Drum.....	46	Trio Drums.....		
“Spirit of 76” Drum.....	47	Trombone Maint. Kits.....		
Staffboard Liner.....	40	Trophy Classics Display.....		
Steel Corners.....	85	Trumpet/Cornet Maint Kit.....		
Sterisol.....	72	Trumpet Valve Protector.....		
Stirring Drum.....	46	Truss Rod Wrench.....		
Stop Tailpiece.....	29	Tunable Bongos.....		
Strap Buttons.....	27	Tuning Hammer, Autoharp.....		
Strap Locks.....	27	Tuning Hammer, Piano.....		
Strings Adjusters		Twin Tone Block.....		
Cello.....	97	U		
Viola.....	97	Ukulele.....		92
Violin.....	101	Ukulele Bag.....		92
Super Snare, 42 Strand.....	67	Ukulele Picks.....		93

GROVER/TROPHY MUSICAL PRODUCTS
CLEVELAND, OH 44125 U.S.A.
www.Grotro.com Email: Music@grotro.com

©2020 Grover Musical Products Inc., All rights reserved.
Copyright information: Certain names, logos, designs, titles, words or phrases used in these pages may constitute trademarks of Grover Musical Products Inc., or other entities, which may be registered in certain jurisdictions.